



PIATTAFORME AEREE SEMOVENTI  
SELF-PROPELLED WORK-PLATFORMS  
PLATES-FORMES DE TRAVAIL AUTOMOTRICES  
SELBSTFAHRENDE HUBARBEITSBÜHNEN  
PLATAFORMAS ELEVADORAS AUTOPROPULSADAS  
ZELFRIJDENDE HOOGWERKERS  
SJÄLVGÅENDE ARBETSPLATTFORMAR  
SAMOKRETNE RADNE PLATFORME

**"A" SERIES**  
**A21 J    A23 J**



**USE AND MAINTENANCE MANUAL**  
**- ENGLISH - ORIGINAL INSTRUCTIONS**

*AIRO* is a division of **TIGIEFFE SRL**  
Via Villasperiore, 82 - 42045 Luzzara (RE) ITALY-  
☎ +39-0522-977365 - 📠 +39-0522-977015  
WEB: [www.airo.com](http://www.airo.com)

Revision date	Description of revision
2010-01	<ul style="list-style-type: none"> <li>• Update due to new machine directive 2006/42/EC.</li> <li>• Model names updated.</li> </ul>
2010-11	<ul style="list-style-type: none"> <li>• Biodegradable oil instructions introduced.</li> <li>• Temperatures and oil list updated.</li> </ul>
05-2011	<ul style="list-style-type: none"> <li>• Amended information on "Commissioning and first inspection, subsequent inspections and title transfer report".</li> <li>• Inserted "Total quantity of battery electrolyte" in Technical Data.</li> <li>• Corrected "Max. power" diesel engine and inserted "Adjusted Power".</li> </ul>
08-2011	<ul style="list-style-type: none"> <li>• Changed wiring diagram, inserted in the second part of the manual, after replacing the converter 48V-12V of the installations JE.</li> </ul>
11-2012	<ul style="list-style-type: none"> <li>• Buttons description and enable selectors of 12Vdc and 380Vac three phase optional electrical pumps changed.</li> </ul>
2013-10	<ul style="list-style-type: none"> <li>• Specified instructions for harness anchoring points.</li> </ul>
2014-09	<ul style="list-style-type: none"> <li>• Inserted information on maximum limits of manual forces.</li> <li>• Changed Name and Surname of CEO.</li> </ul>
2015-01	<ul style="list-style-type: none"> <li>• CE Conformity Declaration Updated.</li> <li>• Hand Position Instruction Added.</li> </ul>
2015-10	<ul style="list-style-type: none"> <li>• Type of usable hydraulic oil updated.</li> <li>• Added indication for spare parts. They must be original or approved by the manufacturer of the machine.</li> <li>• Added "Leaving at height".</li> </ul>
2016-08	<ul style="list-style-type: none"> <li>• Inclinator in platform deleted from standard equipment, becomes optional.</li> <li>• Behaviour x M11 and M12 with machine lifted updated.</li> </ul>
2018-05	<ul style="list-style-type: none"> <li>• Data sheets were added with units of measurement of the international system and US unit of measurement.</li> <li>• Changed Name and Surname of CEO.</li> <li>• Unified First and Second Part.</li> </ul>

**Tigieffe** thanks you for purchasing a product of its range, and invites you to read this manual. Here you can find all the necessary information for a correct use of the purchased machine; therefore, you are advised to follow the instructions carefully and to read the manual thoroughly. The manual should be kept in a suitable place where no damage can occur to it. The content of this manual may be modified without prior notice and further obligations in order to add changes and improvements to the units already delivered. No reproduction or translation may take place without the written permission of the owner.

## Contents:

<b>1. INTRODUCTION .....</b>	<b>6</b>
1.1. LEGAL ASPECTS .....	6
1.1.1. <i>Delivery of the machine</i> .....	6
1.1.2. <i>Declaration of commissioning, first check, further periodical checks and transfers of ownership</i> .....	6
1.1.2.1. Declaration of commissioning and first check .....	6
1.1.2.2. Further periodical checks .....	7
1.1.2.3. Transfers of ownership .....	7
1.1.3. <i>Operator training and information</i> .....	7
1.2. TESTS PERFORMED BEFORE DELIVERY .....	7
1.3. INTENDED USE .....	7
1.3.1. <i>Leaving at height</i> .....	8
1.4. DESCRIPTION OF THE MACHINE .....	8
1.5. CONTROL PANELS .....	9
1.6. DRIVE POWER .....	9
1.7. MACHINE LIFE, DEMOLITION AND DECOMMISSIONING .....	9
1.8. IDENTIFICATION .....	10
1.9. LOCATION OF MAIN COMPONENTS .....	11
<b>2. TECHNICAL FEATURES OF STANDARD MACHINES.....</b>	<b>12</b>
2.1. MODEL A21 JRTD .....	12
2.2. MODEL A21 JRTE .....	14
2.3. MODEL A23 JRTD .....	17
2.4. MODEL A23 JRTE .....	19
2.5. VIBRATIONS AND NOISE .....	22
<b>3. SAFETY PRECAUTIONS.....</b>	<b>23</b>
3.1. PERSONAL PROTECTIVE EQUIPMENT (PPE) .....	23
3.2. GENERAL SAFETY NORMS .....	23
3.3. USE INSTRUCTIONS .....	24
3.3.1. <i>General</i> .....	24
3.3.2. <i>Handling</i> .....	24
3.3.3. <i>Operating procedures</i> .....	26
3.3.4. <i>Wind speed according to Beaufort scale</i> .....	27
3.3.5. <i>Pressure of the machine on ground and load-bearing capacity of ground</i> .....	28
3.3.6. <i>High-voltage power lines</i> .....	29
3.4. HAZARDOUS SITUATIONS AND/OR ACCIDENTS .....	29
<b>4. INSTALLATION AND PRELIMINARY CHECKS.....</b>	<b>30</b>
4.1. BECOMING ACQUAINTED WITH THE MACHINE .....	30
4.2. PRELIMINARY OPERATION CHECKS .....	30
<b>5. HOW TO USE.....</b>	<b>31</b>
5.1. PLATFORM CONTROL PANEL .....	31
5.1.1. <i>Drive and steering</i> .....	33
5.1.2. <i>Platform Positioning Movements</i> .....	35
5.1.2.1. Pantograph (lower boom) lifting/lowering .....	35
5.1.2.2. Upper boom lifting/lowering .....	35
5.1.2.3. Jib lifting/lowering .....	35
5.1.2.4. Telescopic boom extension/retraction .....	36
5.1.2.5. QUICK UP/QUICK DOWN (OPTIONAL) .....	36
5.1.2.6. Turret orientation (rotation) .....	36
5.1.2.7. Jib rotation (OPTIONAL) .....	36
5.1.2.8. Platform rotation .....	37

5.1.2.9.	Platform levelling.....	37
5.1.3.	<i>Other functions of the platform control panel</i> .....	38
5.1.3.1.	Electric/thermic power selection, electrical ac/electrical dc.....	38
5.1.3.2.	Electric power selector 12V (Battery) or 230V/380V three-phase (power mains) - (OPTIONAL).....	38
5.1.3.3.	Electrical pump start button 12V (Battery) or 230V/380V three-phase mains (power mains) - (OPTIONAL).....	38
5.1.3.4.	Three-phase 380V electric pump warning light lit up.....	38
5.1.3.5.	Heat engine start switch ( "ED", "D" models).....	38
5.1.3.6.	Manual horn.....	39
5.1.3.7.	Emergency stop button.....	39
5.1.3.8.	Warning lights.....	39
5.1.3.8.1.	Enabled control panel green warning light (ZA).....	39
5.1.3.8.2.	Flat battery red warning light (ZB) – electric models only.....	39
5.1.3.8.3.	Diesel engine fault / low fuel red warning light (ZC).....	39
5.1.3.8.4.	Danger red warning light (ZD).....	40
5.1.3.8.5.	Overload red warning light (ZE).....	40
5.2.	GROUND CONTROL PANEL (ELECTRIC CONTROL UNIT).....	41
5.2.1.	<i>On-off key and control panel selector (A)</i> .....	42
5.2.2.	<i>Emergency stop button (B)</i> .....	42
5.2.3.	<i>Diesel/electric drive power selector (C)</i> .....	42
5.2.4.	<i>Heat motor start button (D)</i> .....	42
5.2.5.	<i>User interface display (E)</i> .....	43
5.2.6.	<i>Battery charger warning light (F)</i> .....	43
5.2.7.	<i>Enabled control panel warning light (G)</i> .....	43
5.2.8.	<i>Diesel engine warning lights (H L M N)</i> .....	43
5.2.9.	<i>Platform control levers</i> .....	43
5.3.	PLATFORM ACCESS.....	44
5.4.	MACHINE START-UP.....	44
5.4.1.	<i>Diesel engine start-up</i> .....	45
5.4.2.	<i>Start-up of 380V work electrical pump (OPTIONAL)</i> .....	46
5.4.3.	<i>Start-up of 12V emergency electric pump (OPTIONAL for models "D")</i> .....	47
5.5.	MACHINE STOP.....	48
5.5.1.	<i>Normal stop</i> .....	48
5.5.2.	<i>Emergency stop button</i> .....	48
5.5.3.	<i>Diesel engine stop</i> .....	48
5.5.4.	<i>Stopping the 380V three-phase or 230V single-phase electrical pump (optional)</i> .....	49
5.6.	EMERGENCY MANUAL CONTROLS.....	50
5.7.	SOCKET FOR ELECTRIC TOOL CONNECTION (OPTIONAL).....	51
5.8.	FUEL LEVEL AND RE-FUELLING (MODELS "ED", "D").....	51
5.9.	END OF WORK.....	52
<b>6.</b>	<b>HANDLING AND CARRYING.....</b>	<b>53</b>
6.1.	HANDLING.....	53
6.2.	CARRYING.....	54
6.3.	EMERGENCY TOWING OF THE MACHINE.....	56
<b>7.</b>	<b>MAINTENANCE.....</b>	<b>57</b>
7.1.	MACHINE CLEANING.....	57
7.2.	GENERAL MAINTENANCE.....	58
7.2.1.	<i>Various adjustments</i> .....	59
7.2.2.	<i>Greasing</i> .....	60
7.2.3.	<i>Hydraulic circuit oil level check and change</i> .....	61
7.2.3.1.	Biodegradable hydraulic oil (Optional).....	62
7.2.3.2.	Emptying.....	62
7.2.3.3.	Filters.....	62
7.2.3.4.	Washing.....	62
7.2.3.5.	Filling.....	62
7.2.3.6.	Commissioning / check.....	62
7.2.3.7.	Mix.....	63
7.2.3.8.	Micro-filtration.....	63
7.2.3.9.	Disposal.....	63
7.2.3.10.	Topping up.....	63
7.2.4.	<i>Hydraulic filter replacement</i> .....	64
7.2.4.1.	Suction filters.....	64
7.2.4.1.1.	Main gear pump filter.....	64

7.2.4.1.2.	Filter of electrical pumps, 380V (OPTIONAL) and 12V (emergency on Diesel models)	65
7.2.4.2.	Return filter	66
7.2.5.	Turret rotation reduction gear oil level check and change	67
7.2.5.1	Checks in the use of synthetic biodegradable oil in turret rotation reduction gears	67
7.2.6.	Drive reduction gear oil level check and change	68
7.2.6.1	Checks in the use of synthetic biodegradable oil in drive reduction gears	68
7.2.7.	Air purging from oscillating axle locking cylinders	69
7.2.8.	Turret rotation clearance adjustment	70
7.2.9.	Telescopic boom sliding blocks clearance adjustment	70
7.2.10.	Visual check of wear condition of chains of boom extraction (A23 J only)	71
7.2.11.	Check/adjustment of tension of chains of telescopic boom extraction (A23 J only)	72
7.2.12.	Circuit movements pressure relief valve operation check	73
7.2.13.	Operation check of the turret inclinometer	74
7.2.14.	Operation check and adjustment of platform overload controller	76
7.2.15.	Overload controller by-pass – ONLY FOR EMERGENCY OPERATIONS	78
7.2.16.	Operation check of M1 microswitches	79
7.2.17.	Operation check of microswitch M9 (OPTIONAL)	80
7.2.18.	Operation check of microswitch and proximity sensor M10	80
7.2.19.	Operation check of proximity sensors M11 and M12 (OPTIONAL)	81
7.2.20.	Operation check of proximity sensor M13 (OPTIONAL)	81
7.2.21.	Operation check of microswitches M14 and M15 (SG2100-J only)	81
7.2.22.	Operation check of dead-man pedal safety system	82
7.3.	STARTING BATTERY	83
7.3.1.	Starter battery models “D” “ED”	83
7.3.2.	Starter type battery for models “E”	83
7.3.3.	Starter battery maintenance	83
7.3.4.	Starter battery recharge	83
7.4.	“DRIVE” BATTERY FOR MODELS “E” AND “ED”	84
7.4.1.	General instructions for DRIVE battery	84
7.4.2.	DRIVE battery maintenance	84
7.4.3.	Battery charger: DRIVE battery recharge	85
7.4.4.	Battery charger: fault report	86
7.4.5.	Battery replacement	86
<b>8 .</b>	<b>MARKS AND CERTIFICATIONS</b>	<b>88</b>
<b>9 .</b>	<b>PLATES AND STICKERS</b>	<b>89</b>
<b>10 .</b>	<b>CHECK REGISTER</b>	<b>91</b>
<b>11.</b>	<b>WIRING DIAGRAMS</b>	<b>112</b>
<b>12.</b>	<b>HYDRAULIC DIAGRAM</b>	<b>124</b>
<b>13.</b>	<b>CONFORMITY DECLARATION</b>	<b>127</b>

# 1. INTRODUCTION

This Use and Maintenance Manual provides general instructions concerning the complete range of machines indicated on the cover. Therefore the description of their components, as well as control and safety systems, may include parts not present on Your machine since supplied on request or not available. In order to keep pace with the technical development **AIRO-Tigieffe s.r.l.** reserves the right to modify the product and/or the use and maintenance manual at any time without updating the units already delivered.

## 1.1. Legal aspects

### 1.1.1. Delivery of the machine

Within EU (European Union) member countries the machine is delivered complete with:

- Use and maintenance manual in your language.
- CE mark applied on the machine.
- CE declaration of conformity.
- Guarantee certificate.

Only for Italy:

- Declaration of commissioning to INAIL.
- List of local INAIL departments.
- Declaration of internal testing.

It is to be noted that the Use and Maintenance Manual is an integral part of the machine and a copy of this, together with copies of the documents certifying that the periodical checks have been carried out, must be kept on board in its suitable container. In the event of a transfer of ownership the machine must always be provided with its use and maintenance manual.

### 1.1.2. Declaration of commissioning, first check, further periodical checks and transfers of ownership

The legal obligations of the owner of the machine vary according to the country of commissioning. It is therefore recommended to inquiry about the procedures in force in your country from the boards responsible for industrial safety. This manual contains a final section called "Check register" for a better filing of documents and recording of any modifications.

#### 1.1.2.1. Declaration of commissioning and first check

In ITALY the owner of the Aerial Platform must notify the use of the machine to the local competent INAIL and submit it to periodical compulsory checks. The first of such checks is performed by the INAIL within sixty days from a request being made. In the event of such time passing without the inspection being made, the employer can call in the ASL (Local Health Unit) or qualified public or private services. Subsequent checks are made by the already-mentioned parties within thirty days from a request being made. In the event of such time passing without these checks being made, the employer can call in qualified public or private services. The checks are on a payment basis and the employer (machine owner) will be charged for them. For these checks, the territorial inspection boards (ASL/USL or ARPA) and INAIL can be supported by qualified public or private services. The qualified private institutes acquire the qualification of responsible for the public service and refer directly to the public structure that controls this function.

To declare the commissioning of the machine in Italy, send the form that is supplied together with other documents upon machine delivery, by registered letter with advice of receipt.

The INAIL will assign a serial number when the First Check is performed before completing the "technical identification sheet" on which it indicates only the details obtained from the already-operating machine or obtainable from the instruction manual. Such document shall form an integral part of the machine documentation.

### 1.1.2.2. Further periodical checks

Yearly checks are compulsory. In Italy the owner of the Aerial Platform must apply for a periodical check by sending a registered letter to the local competent inspection board (ASL/USL or other qualified public or private services) at least twenty days before the expiry of the year from the last check.

NB: If a machine without a valid control document should be moved in an area outside the competence of the usual inspection board, the owner of the machine must ask the inspection board, competent for the new territory where the machine is to be used, for the annual check.

### 1.1.2.3. Transfers of ownership

In case of transfer of ownership (in Italy) the new owner of the Aerial Platform must notify the ownership of the machine to the local competent inspection board (ASL/USL or other qualified public or private services) by enclosing a copy of:

- Declaration of conformity issued by the manufacturer.
- Declaration of commissioning carried out by the first owner.

### 1.1.3. Operator training and information

The employer must ensure that the workers appointed to use the equipment are adequately and specifically trained so they are able to use the Mobile Elevating Work Platform in a proper and safe way and also avoid the risks caused by other people.

## 1.2. Tests performed before delivery

Before being placed on the market, each MEWP undergoes the following tests:

- Braking test.
- Overload test.
- Operating test.

## 1.3. Intended use

The machine described in this use and maintenance manual is a self-propelled aerial platform intended for lifting persons and materials (equipment and work materials) in order to carry out maintenance, installation, cleaning, painting, de-painting, sand-blasting, welding operations, etc.

The max. capacity allowed (which varies according to the model – see paragraph “Technical features”) is divided as follows:

- 80 Kg for each person on board.
- 40 Kg for equipment.
- Any remaining load is represented by the work materials.

In any case NEVER exceed the maximum capacity allowed as indicated in paragraph “Technical features”. Persons, tools and work materials can be loaded on the platform only from the access position (platform lowered). It is absolutely forbidden to load persons, tools and work materials on the platform when it is not in access position.

All loads must be positioned inside the cage. Do not lift loads (even if complying with the maximum capacity allowed) hanging from the platform or lifting structure.

Do not carry large-sized panels since they increase the resistance to wind force thus causing the machine to overturn.

While the machine is being displaced with lifted platform, no horizontal loads can be loaded onto the platform (operators on board are not allowed to pull wires or ropes, etc.).

An overload controller stops the operation of the machine if the load on the platform exceeds by 20% approx. the nominal load (see chapter “General use rules”) and platform is lifted.

The machine cannot be used in areas where road vehicles operate. Always surround the working area by means of suitable signs when the machine is used in public areas.

Do not use the machine to tow trucks or other vehicles.

All types of machine use other than those for which it was designed must be approved in writing by the machine manufacturer following a specific request on the part of the user.



**Do not use the machine for purposes other than those for which it was designed, except after making a request and having obtained written permission in this sense from the manufacturer**

### 1.3.1. Leaving at height

The work elevating platforms are not designed by taking into account the risks of the “leaving at height” because the only access position considered is when the platform is completely lowered. For this reason this activity is formally forbidden.

However, there are exceptional conditions in which the operator needs to access or leave the work platform not in the access position. This activity is normally defined as “leaving at height”.

The risks connected to the “leaving at height” do not depend exclusively on the PLE (work elevating platform) characteristics; a specific risk analysis carried out by the employer can authorize this specific use by taking into account:

- The working environment characteristics.
- The absolute prohibition to consider the work platform as an anchoring point for people working outdoors.
- The use of the machine at xx% of its performances to avoid that additional forces created by a specific operation or bending of the structure move away the access zone from the unloading zone. Provide for some tests in order to define these limitations.
- Provide for a specific evacuation procedure in case of emergency (for example: an operator always on the platform, one at the ground control panel while a third operator leaves the lifted platform ).
- Provide for a specific training of the staff both as operator and transported staff.
- Equip the unloading zone with all the devices that are necessary to avoid the risk of fall of the staff that accesses/leaves the platform.

What said above is not a formal authorization of the manufacturer for the “leaving at height”, but it wants to supply information to the employer - who is fully responsible for that - which can be useful for the planning of this exceptional activity.

## 1.4. Description of the machine

The machine described in this use and maintenance manual is a Mobile Elevating Work Platform equipped with:

- Motorized chassis equipped with wheels.
- Hydraulically driven rotating turret.
- Articulated boom operated by hydraulic cylinders (the number of articulations and cylinders varies according to machine model).
- Operator platform (the max. capacity varies according to the model - see chapter "Technical features").

**The chassis** is motorized to allow the machine to move even when the platform is lifted (see “Use instructions”).

The machines can be delivered with the following drive and steering features:

- Four driving wheels, of which two steering and two fixed.
- Four steering and driving wheels.

Furthermore, to all the above combinations, it is possible to associate, optionally, a self-locking oscillating axle.

All driving wheels are equipped with hydraulic parking brakes, positive logic type (when drive controls are released brakes are automatically activated).

**The turret** rests on a turntable fixed to the chassis and can be oriented (rotated) by 360° continuously around the central axle of the machine by means of geared motor with built-in hydraulic brake.

**The lifting system**, with articulated boom, can be divided into three main structures:

- The first, with vertical extension, consists of a “double parallelogram” system named “pantograph”.
- The second, consists of a lifting boom with telescopic extension.
- The third, consists of the terminal boom named “Jib”.

Such lifting structures are driven by 4 double-acting hydraulic cylinders:

- One cylinder for the “pantograph” extension.
- One cylinder for the boom extension.
- One cylinder for the extension/retraction of the telescopic boom (for A23 J two systems of chains for extraction and retraction of the last extractable boom are also supplied).
- One cylinder for the “jib” extension.



The hydraulic cylinders which move the articulated structure (except for the boom inclination sensor cylinder) are provided with over-centre valves directly flanged on the same. These devices allow the booms to remain in position even if one of the supply tubes accidentally breaks.

**The platform**, hinged to the end of the “jib”, can be rotated by 180° totally (90° on the right and 90° on the left) by means of a rotary actuator fitted with over-centre valve. It is fitted with guardrails and toe boards of prescribed height (the guardrails height  $\geq$  1100 mm; the toe boards height  $\geq$  150 mm). The platform levelling is automatic and is ensured by mechanical ties and two cylinders in closed circuit. The manual level compensation is possible by acting on the relevant control only with completely lowered booms (and with “Jib” inclination with respect to the horizontal axle ranging between +10° and -70°).

## 1.5. Control panels

The machine is equipped with two control panels:

- On the platform for normal use of the machine.
- On the turret (or on the ground) you can find the emergency controls to lower or stop the machine in emergency situations, a key-selector to select the control panel and to start the machine.

## 1.6. Drive power

The machines can be powered by:

- An electric-hydraulic system composed of rechargeable accumulators and electrical pump (models “E”).
- A heat engine (Diesel engine models are identified by the abbreviation “D”; petrol engine models are identified by the abbreviation “B”).
- A dual-powered electric/thermic system (dual-powered Electric/Diesel models are identified by the abbreviation “ED”; dual-powered Electric/Petrol models are identified by the abbreviation “EB”).

In any case both the hydraulic and the electric systems are equipped with all necessary protections (see electric and hydraulic circuit diagrams annexed to this manual).

## 1.7. Machine life, demolition and decommissioning

The machine has been designed to last for 10 years in normal operating environments, if properly used and serviced. Within this period, the manufacturer must carry out a complete inspection/overhaul.

If disposal of the unit is necessary, comply with current local regulations.

In Italy, the demolition/decommissioning must be notified to the local ASL / USL or ARPA.

The machine consists mainly of metal parts which are easy to be identified (steel for the most parts, and aluminium for the hydraulic blocks); thus, we can state that the machine can be recycled at 90%.



**European standards and those transposed by the member countries relating to respect for the environment and the disposal of wastes envisage heavy administrative and penal fines in case of infringement. In case of demolition/decommissioning, carefully keep to the provisions of applicable regulations, especially as regards materials such as hydraulic oil and batteries.**

### 1.8. Identification

In order to identify the machine, when spare parts and service are required, always mention the information given in the serial number plate. Should this plate (as well as the various stickers applied on the machine) be lost or illegible, it is to be replaced as soon as possible. In order to identify the machine when no plate is available the serial number is also stamped on the chassis. To locate the plate and the stamp of the serial number, see the following picture. It is recommended to copy such data in the following boxes.

MODEL: _____	CHASSIS: _____	YEAR: _____
--------------	----------------	-------------



Fig. 1

## 1.9. Location of main components

The picture shows the machine and its own components.

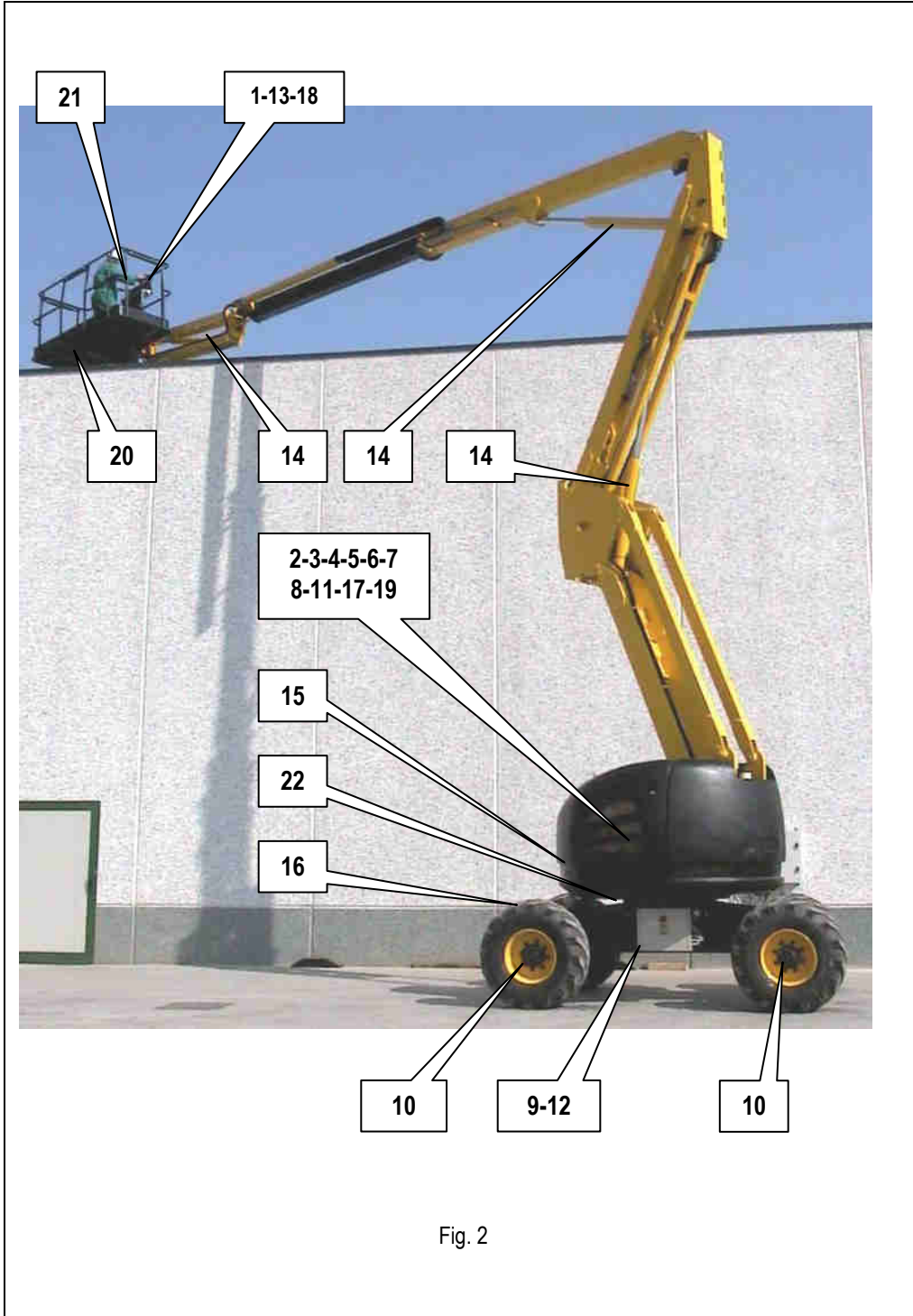

- 1) Control panel
- 2) Electric control unit
- 3) Hydraulic oil tank
- 4) Diesel tank (models "D")
- 5) Diesel Engine (models "D")
- 6) Drive pump
- 7) Movement pump
- 8) 12V emergency electrical pump (optional on models "D")
- 9) 380V three-phase electrical pump (optional)
- 10) Hydraulic drive motors
- 11) Turret rotation geared motor
- 12) 230V plug (optional)
- 13) Spirit level (optional) for visual check of machine levelling
- 14) Lifting cylinders
- 15) Battery
- 16) Power assisted steering
- 17) Base inclinometer
- 18) Inclinometer cage (optional)
- 19) Heat motor fuel tank
- 20) Limiting sensors of platform load
- 21) Control board of platform load
- 22) Turntable

Fig. 2

## 2. TECHNICAL FEATURES OF STANDARD MACHINES



THE TECHNICAL FEATURES OF THE PRODUCTS IN THE FOLLOWING PAGES CAN BE MODIFIED WITHOUT PRIOR NOTICE

### 2.1. Model A21 JRTD

		A21 JRTD			
<b>Dimensions:</b>					
Maximum working height	20.55	m	67' 5"	ft	
Max. platform height	18.55	m	60' 10"	ft	
Ground clearance	480	mm	1.6"	in	
Max. outreach from turntable centre	11.3	m	37' 0"	ft	
Turret rotation (continuous)	360	°	360	°	
Platform rotation	180	°	180	°	
Platform height for safety speed activation	< 3	m	<9' 10"	ft	
Internal steering radius– 2WS	3.2	m	10' 4"	ft	
External steering radius– 2WS	6	m	19' 6"	ft	
Internal steering radius– 4WS	1.7	m	5' 6"	ft	
External steering radius– 4WS	4.1	m	13' 5"	ft	
Maximum capacity (m)	230	Kg	500	lbs	
Max. number of people on the platform (n) – indoors	2		2		
The tool and material weight (me) (**) – indoors	70	Kg	154.5	lbs	
Max. number of people on the platform (n) – outdoors	2		2		
Tool and material weight (me) (**) – outdoors	70	Kg	154.5	lbs	
Maximum drive height	Max		Max		
Maximum dimensions of platform (****)	0.8 x 1.7	m	2' 7" x 5' 6"	ft	
Max. hydraulic pressure	350	Bar	5076.3	psi	
Max. pressure of lifting circuit	230	Bar	3335.8	psi	
Tyre dimensions (****)	Ø 1010 x 405	mm	3' 3" x 1' 3"	in	
Tyre type (****)	15 x 19,5-12		15 x 19,5 16PR		
Transport dimensions	7.96 x 2.40 x 2.65	m	26' 1" x 7' 10" x 8' 8"	ft	
Transport dimensions with retracted jib	N.A.	m	N.A.	ft	
Machine weight (unloaded) (*)	12250	Kg	27006.6	lbs	
<b>Stability limit:</b>					
Longitudinal inclination	4	°	4	°	
Transversal inclination	4	°	4	°	
Maximum wind speed (***)	12.5	m/s	28	mph	
Maximum manual force:	400	N	90	lbf	
Max. load per wheel	5200	Kg	11450	lbs	
<b>Performance:</b>					
Drive wheels	4	N	4	N	
Max. drive speed	6.1	km/h	3.7	mph	
Safety drive speed	0.6	km/h	0.3	mph	
Oil tank capacity	120	Lt.	31.7	gal	
Gradeability	50	%	50	%	
Max. operating temperature	+50	°C	122	°F	
Min. operating temperature	-15	°C	5	°F	

<b>Battery power:</b>					
Battery capacity and voltage	NA	V/Ah	NA	V/Ah	
Battery weight	NA	Kg	NA	lbs	
Single-phase battery charger (HF)	NA	V/A	NA	V/A	
Max. current absorbed by the battery charger	NA	A	NA	A	
Max. installed power	NA	kW	NA	hp	
Electrical pump power 1	NA	kW	NA	hp	
Max. absorbed current	NA	A	NA	A	
Power electric pump 2	NA	kW	NA	hp	
Max. absorbed current	NA	A	NA	A	
Power electric pump 3	NA	kW	NA	hp	
Max. absorbed current	NA	A	NA	A	

<b>Diesel Power HATZ</b>					
Diesel engine type	HATZ 3L41C			HATZ 3L41C	
Max. motor power	38.8	kW	52.0	hp	
Adjusted Power	35.5	kW	47.6	hp	
Starter battery	12 / 180	V/Ah	12 / 180	V/Ah	
Total electrolyte quantity	11	Lt.	3.9	gal	
Diesel oil tank capacity	70	Lt.	18.4	gal	
<b>Diesel Power ISUZU</b>					
Diesel engine type	ISUZU 4LE1				
Max. motor power	39	kW	52.2	hp	
Adjusted Power	35	kW	46.9	hp	
Starter battery	12 / 180	V/Ah	12 / 180	V/Ah	
Total electrolyte quantity	11	Lt.	3.9	gal	
Diesel oil tank capacity	70	Lt.	18.4	gal	
<b>380V three-phase electrical pump (optional)</b>					
Motor power	7.5	kW			
Max. absorbed current	12	A	12	hp	
Max. drive speed	NA	km/h	12	A	
<b>230V single-phase electric pump (optional)</b>					
Motor power	2.2	kW			2.9
Max. absorbed current	13.9	A	13.9	A	
Max. drive speed	NA	km/h	NA	mph	

NOTE: These abbreviations 2WS; 4WS are not indicated on the machine plates. They stand for:

- 2WS= Four driving wheels, two steering wheels
- 4WS= Four driving wheels, four steering wheels

(\*) In some cases different limits can be fixed. It is recommended to comply with the data shown on the machine plate. Weight A21 JRTD 2WS = 12250 kg; Weight A21 JRTD 4WS = 12400 kg.

(\*\*)  $me = m - (n \times 80)$

(\*\*\*) Wind speeds higher or equal to 12.5 m/s indicate that the machines can also be used outdoors; Wind speeds equal to 0 m/s indicate that the machines can be used INDOORS ONLY.

(\*\*\*\*) Standard rough terrain tyres 15x19.5-16PR (Ø1010x405 mm) ) filled with polyurethane foam; Optional rough terrain tyres 18x19.5-16PR (Ø1080x460 mm) filled with polyurethane foam.

(\*\*\*\*\*) 800x1700 mm standard steel platform; Optional larger 900x2400 mm steel platform; Optional larger 1000x2400 mm steel platform.

## 2.2. Model A21 JRTE

		A21 JRTE			
<b>Dimensions:</b>					
Maximum working height		20.55	m	67' 5"	ft
Max. platform height		18.55	m	60' 10"	ft
Ground clearance		480	mm	1.6"	in
Max. outreach from turntable centre		11.3	m	37"	ft
Turret rotation (continuous)		360	°	360	°
Platform rotation		180	°	180	°
Platform height for safety speed activation		< 3	m	<9' 10"	ft
Internal steering radius– 2WS		3.2	m	10' 5"	ft
External steering radius– 2WS		6	m	19' 8"	ft
Internal steering radius– 4WS		1.7	m	5' 6"	ft
External steering radius– 4WS		4.1	m	13' 5"	ft
Maximum capacity (m)		230	Kg	507.0	lbs
Max. number of people on the platform (n) – indoors		2		2	
The tool and material weight (me) (**) – indoors		70	Kg	154.5	lbs
Max. number of people on the platform (n) – outdoors		2		2	
Tool and material weight (me) (**) – outdoors		70	Kg	154.5	lbs
Maximum drive height		Max		Max	
Maximum dimensions of platform (****)		0.8 x 1.7	m	2' 7" X 5' 6"	ft
Max. hydraulic pressure		350	Bar	5076.3	psi
Max. pressure of lifting circuit		230	Bar	3335.8	psi
Tyre dimensions (****)		Ø 1010 x 405	mm	39' 3" x 15' 9"	in
Tyre type (****)		15 x 19,5-12		15 x 19,5 16PR	
Transport dimensions		7.96 x 2.40 x 2.65	m	26' 1" x 7' 10" x 8' 3"	ft
Transport dimensions with retracted jib		N.A.	m	N.A.	ft
Machine weight (unloaded) (*)		13000	Kg	28660	lbs
<b>Stability limit:</b>					
Longitudinal inclination		4	°	4	°
Transversal inclination		4	°	4	°
Maximum wind speed (***)		12.5	m/s	28	mph
Maximum manual force:		400	N	90	lbf
Max. load per wheel		5200	Kg	11450	lbs
<b>Performance:</b>					
Drive wheels		4	N	4	N
Max. drive speed		2.9	km/h	3.7	mph
Safety drive speed		0.6	km/h	0.3	mph
Oil tank capacity		120	Lt.	31.5	gal
Gradeability		30	%	50	%
Max. operating temperature		+50	°C	122	°F
Min. operating temperature		-15	°C	5	°F
<b>Battery power:</b>					
Battery capacity and voltage		48 / 750	V/Ah	V/Ah	V/Ah
Total electrolyte quantity		168	Lt.	44.3	gal
Battery weight		1315	Kg	2899.0	lbs
Three-phase battery charger 380V (HF)		48 / 80	V/A	V/A	V/A
Max. current absorbed by the battery charger		14	A	14	A
Max. installed power		17	kW	22.7	hp
Power electric pump 1		17	kW	22.7	hp
Max. absorbed current		400	A	400	A
Power electric pump 2		NA	kW	NA	hp
Max. absorbed current		NA	A	NA	A
Power electric pump 3		NA	kW	NA	hp
Max. absorbed current		NA	A	NA	A

<b>Diesel Power HATZ</b>				
	Diesel engine type	NA		NA
	Motor power	NA	kW	NA hp
	Starter battery	NA	V/Ah	NA V/Ah
	Diesel oil tank capacity	NA	Lt.	NA gal
<b>Diesel Power ISUZU</b>				
	Diesel engine type	NA		NA
	Motor power	NA	kW	NA hp
	Starter battery	NA	V/Ah	NA V/Ah
	Diesel oil tank capacity	NA	Lt.	NA gal
<b>380V three-phase electrical pump (optional)</b>				
	Motor power	NA	kW	NA hp
	Max. absorbed current	NA	A	NA A
	Max. drive speed	NA	km/h	NA mph
<b>230V single-phase electric pump (optional)</b>				
	Motor power	NA	kW	NA hp
	Max. absorbed current	NA	A	NA A
	Max. drive speed	NA	km/h	NA mph

NOTE: These abbreviations 2WS; 4WS are not indicated on the machine plates. They stand for:

- 2WS= Four driving wheels, two steering wheels
- 4WS= Four driving wheels, four steering wheels

(\*) In some cases different limits can be fixed. It is recommended to comply with the data shown on the machine plate. Weight A21 JRTE 2WS = 13000 kg; Weight A21 JRTE 4WS = 13150 kg.

(\*\*)  $me = m - (n \times 80)$

(\*\*\*) Wind speeds higher or equal to 12.5 m/s indicate that the machines can also be used outdoors; Wind speeds equal to 0 m/s indicate that the machines can be used INDOORS ONLY.

(\*\*\*\*) Standard rough terrain tyres 15x19.5-16PR (Ø1010x405 mm) ) filled with polyurethane foam; Optional rough terrain tyres 18x19.5-16PR (Ø1080x460 mm) filled with polyurethane foam.

(\*\*\*\*\*) 800x1700 mm standard steel platform; Optional larger 900x2400 mm steel platform; Optional larger 1000x2400 mm steel platform.

A21 JR TD  
A21 JR TE

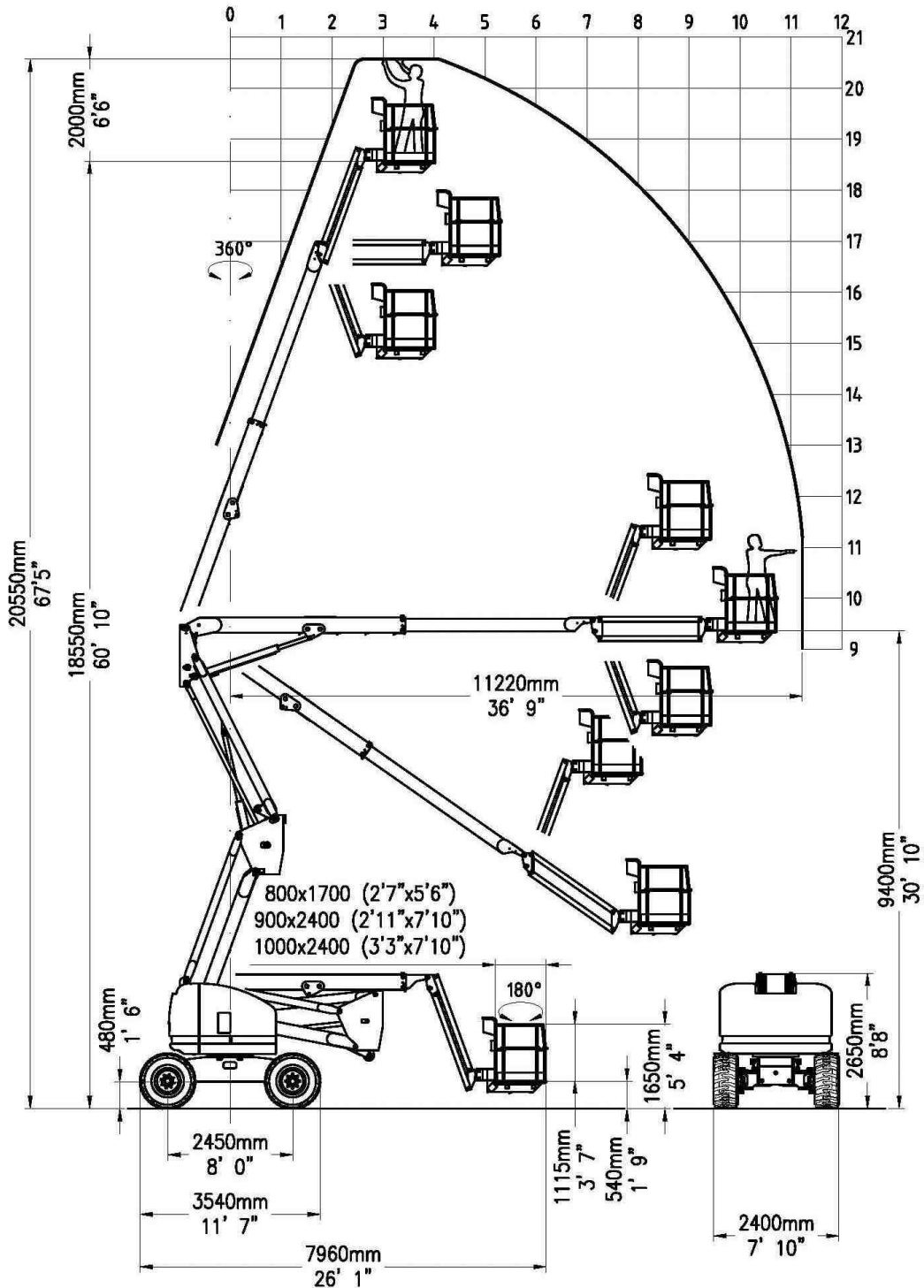
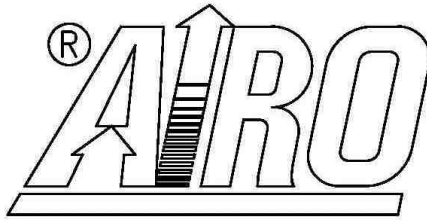



## 2.3. Model A23 JRTD

		A23 JRTD			
<b>Dimensions:</b>					
Maximum working height		23.1	m	75' 9"	ft
Max. platform height		21.1	m	69' 2"	ft
Ground clearance		480	mm	1' 6"	in
Max. outreach from turntable centre		13.9	m	45' 7"	ft
Turret rotation (continuous)		360	°	360	°
Platform rotation		180	°	180	°
Platform height for safety speed activation		< 3	m	<9' 10"	ft
Internal steering radius– 2WS		3.2	m	10' 4"	ft
External steering radius– 2WS		6	m	19' 8"	ft
Internal steering radius– 4WS		1.7	m	5' 6"	ft
External steering radius– 4WS		4.1	m	13' 5"	ft
Maximum capacity (m)		230	Kg	507.0	lbs
Max. number of people on the platform (n) – indoors		2		2	
The tool and material weight (me) (**) – indoors		70	Kg	154.3	lbs
Max. number of people on the platform (n) – outdoors		2		2	
Tool and material weight (me) (**) – outdoors		70	Kg	154.3	lbs
Maximum drive height		Max		Max	
Maximum dimensions of platform (****)		0.8 x 1.7	m	2' 7" x 5' 6"	ft
Max. hydraulic pressure		350	Bar	5076.3	
Max. pressure of lifting circuit		230	Bar	3335.8	
Tyre dimensions (****)		Ø 1010 x 405	mm	3' 3" X 1' 3"	in
Tyre type (****)		15 x 19,5-12		15 x 19,5 16PR	
Transport dimensions		7.9 x 2.40 x 2.65	m	25' 11" x 7' 10" x 8' 8"	ft
Transport dimensions with retracted jib		N.A.	m	N.A	ft
Machine weight (unloaded) (*)		14300	Kg	31526.1	lbs
<b>Stability limit:</b>					
Longitudinal inclination		4	°	4	°
Transversal inclination		4	°	4	°
Maximum wind speed (***)		12.5	m/s	28	mph
Maximum manual force:		400	N	90	lbf
Max. load per wheel		6000	Kg	13220	lbs
<b>Performance:</b>					
Drive wheels		4	N	4	N
Max. drive speed		6.1	km/h	3.7	mph
Safety drive speed		0.6	km/h	0.3	mph
Oil tank capacity		120	Lt.	31.7	gal
Gradeability		50	%	50	%
Max. operating temperature		+50	°C	122	°F
Min. operating temperature		-15	°C	5	°F
<b>Battery power:</b>					
Battery capacity and voltage		NA	V/Ah	NA	V/Ah
Battery weight		NA	Kg	NA	lbs
Single-phase battery charger (HF)		NA	V/A	NA	V/A
Max. current absorbed by the battery charger		NA	A	NA	A
Max. installed power		NA	kW	NA	hp
Power electric pump 1		NA	kW	NA	hp
Max. absorbed current		NA	A	NA	A
Power electric pump 2		NA	kW	NA	hp
Max. absorbed current		NA	A	NA	A
Power electric pump 3		NA	kW	NA	hp
Max. absorbed current		NA	A	NA	A

<b>Diesel Power HATZ</b>					
	Diesel engine type	HATZ 3L41C		HATZ 3L41C	
	Max. motor power	38.8	kW	52.0	hp
	Adjusted Power	35.5	kW	47.6	hp
	Starter battery	12 / 180	V/Ah	12 / 180	V/Ah
	Total electrolyte quantity	11	Lt.	3.9	gal
	Diesel oil tank capacity	70	Lt.	18.4	gal
<b>Diesel Power ISUZU</b>					
	Diesel engine type	ISUZU 4LE1		ISUZU 4LE1	
	Max. motor power	39	kW	52.2	hp
	Adjusted Power	35	kW	46.9	hp
	Starter battery	12 / 180	V/Ah	12 / 180	V/Ah
	Total electrolyte quantity	11	Lt.	3.9	gal
	Diesel oil tank capacity	70	Lt.	18.4	gal
<b>380V three-phase electrical pump (optional)</b>					
	Motor power	7.5	kW	10.5	hp
	Max. absorbed current	12	A	12	A
	Max. drive speed	NA	km/h	NA	mph
<b>230V single-phase electric pump (optional)</b>					
	Motor power	2.2	kW	2.9	hp
	Max. absorbed current	13.9	A	13.9	A
	Max. drive speed	NA	km/h	NA	mph

NOTE: These abbreviations 2WS; 4WS are not indicated on the machine plates. They stand for:

- 2WS= Four driving wheels, two steering wheels
- 4WS= Four driving wheels, four steering wheels

(\*) In some cases different limits can be fixed. It is recommended to comply with the data shown on the machine plate. Weight A23 JRTD 2WS = 14300 kg; Weight A23 JRTD 4WS = 14450 kg.

(\*\*)  $me = m - (n \times 80)$

(\*\*\*) Wind speeds higher or equal to 12.5 m/s indicate that the machines can also be used outdoors; Wind speeds equal to 0 m/s indicate that the machines can be used INDOORS ONLY.

(\*\*\*\*) Standard rough terrain tyres 15x19.5-16PR (Ø1010x405 mm) filled with polyurethane foam; Optional rough terrain tyres 18x19.5-16PR (Ø1080x460 mm) filled with polyurethane foam.

(\*\*\*\*\*) 800x1700 mm standard steel platform; Optional larger 900x2400 mm steel platform; Optional larger 1000x2400 mm steel platform.

## 2.4. Model A23 JRTE

		A23 JRTE			
<b>Dimensions:</b>					
Maximum working height		23.1	m	75' 9"	ft
Max. platform height		21.1	m	69' 2"	ft
Ground clearance		480	mm	18.8"	in
Max. outreach from turntable centre		13.9	m	45' 6"	ft
Turret rotation (continuous)		360	°	360	°
Platform rotation		180	°	180	°
Platform height for safety speed activation		< 3	m	9' 8"	ft
Internal steering radius– 2WS		3.2	m	10' 4"	ft
External steering radius– 2WS		6	m	19' 6"	ft
Internal steering radius– 4WS		1.7	m	5' 5"	ft
External steering radius– 4WS		4.1	m	42' 6"	ft
Maximum capacity (m)		230	Kg	507.0	lbs
Max. number of people on the platform (n) – indoors		2		2	
The tool and material weight (me) (**) – indoors		70	Kg	154.3	lbs
Max. number of people on the platform (n) – outdoors		2		2	
Tool and material weight (me) (**) – outdoors		70	Kg	154.3	lbs
Maximum drive height		Max		Max	
Maximum dimensions of platform (****)		0.8 x 1.7	m	2' 6" x 5' 5"	ft
Max. hydraulic pressure		350	Bar	5076.3	psi
Max. pressure of lifting circuit		230	Bar	3335.8	psi
Tyre dimensions (****)		Ø 1010 x 405	mm	39' 3" x 15' 9"	in
Tyre type (****)		15 x 19,5-12		15 x 19,5 16PR	
Transport dimensions		7.9 x 2.40 x 2.65	m	25' 9" x 7' 8" x 8' 5"	ft
Transport dimensions with retracted jib		N.A.	m	N.A.	ft
Machine weight (unloaded) (*)		15100	Kg	33289.8	lbs
<b>Stability limit:</b>					
Longitudinal inclination		4	°	4	°
Transversal inclination		4	°	4	°
Maximum wind speed (***)		12.5	m/s	28	mph
Maximum manual force:		400	N	90	lbf
Max. load per wheel		6000	Kg	13220	lbs
<b>Performance:</b>					
Drive wheels		4	N	4	N
Max. drive speed		2.9	km/h	1.8	mph
Safety drive speed		0.6	km/h	0.3	mph
Oil tank capacity		120	Lt.	31.7	gal
Gradeability		30	%	50	%
Max. operating temperature		+50	°C	122	°F
Min. operating temperature		-15	°C	5	°F
<b>Battery power:</b>					
Battery capacity and voltage		48 / 750	V/Ah	V/Ah	V/Ah
Total electrolyte quantity		168	Lt.	44.3	gal
Battery weight		1315	Kg	2899.0	lbs
Three-phase battery charger 380V (HF)		48 / 80	V/A	V/A	V/A
Max. current absorbed by the battery charger		14	A	14	A
Max. installed power		17	kW	22.7	hp
Power electric pump 1		17	kW	22.7	hp
Max. absorbed current		400	A	400	A
Power electric pump 2		NA	kW	NA	hp
Max. absorbed current		NA	A	NA	A
Power electric pump 3		NA	kW	NA	hp
Max. absorbed current		NA	A	NA	A

<b>Diesel Power HATZ</b>					
	Diesel engine type	NA		NA	
	Motor power	NA	kW	NA	hp
	Starter battery	NA	V/Ah	NA	V/Ah
	Diesel oil tank capacity	NA	Lt.	NA	gal
<b>Diesel Power ISUZU</b>					
	Diesel engine type	NA		NA	
	Motor power	NA	kW	NA	hp
	Starter battery	NA	V/Ah	NA	V/Ah
	Diesel oil tank capacity	NA	Lt.	NA	gal
<b>380V three-phase electrical pump (optional)</b>					
	Motor power	NA	kW	NA	hp
	Max. absorbed current	NA	A	NA	A
	Max. drive speed	NA	km/h	NA	mph
<b>230V single-phase electric pump (optional)</b>					
	Motor power	NA	kW	NA	hp
	Max. absorbed current	NA	A	NA	A
	Max. drive speed	NA	km/h	NA	mph

NOTE: These abbreviations 2WS; 4WS are not indicated on the machine plates. They stand for:

- 2WS= Four driving wheels, two steering wheels
- 4WS= Four driving wheels, four steering wheels

(\* ) In some cases different limits can be fixed. It is recommended to comply with the data shown on the machine plate. Weight A23 JRTE 2WS = 15100 kg; Weight A23 JRTE 4WS = 15250 kg.

( \*\* )  $me = m - (n \times 80)$

(\*\*\*) Wind speeds higher or equal to 12.5 m/s indicate that the machines can also be used outdoors; Wind speeds equal to 0 m/s indicate that the machines can be used INDOORS ONLY.

(\*\*\*\*) Standard rough terrain tyres 15x19.5-16PR (Ø1010x405 mm ) filled with polyurethane foam; Optional rough terrain tyres 18x19.5-16PR (Ø1080x460 mm) filled with polyurethane foam.

(\*\*\*\*\*) 800x1700 mm standard steel platform; Optional larger 900x2400 mm steel platform; Optional larger 1000x2400 mm steel platform.

# A23 JRTD A23 JRTE

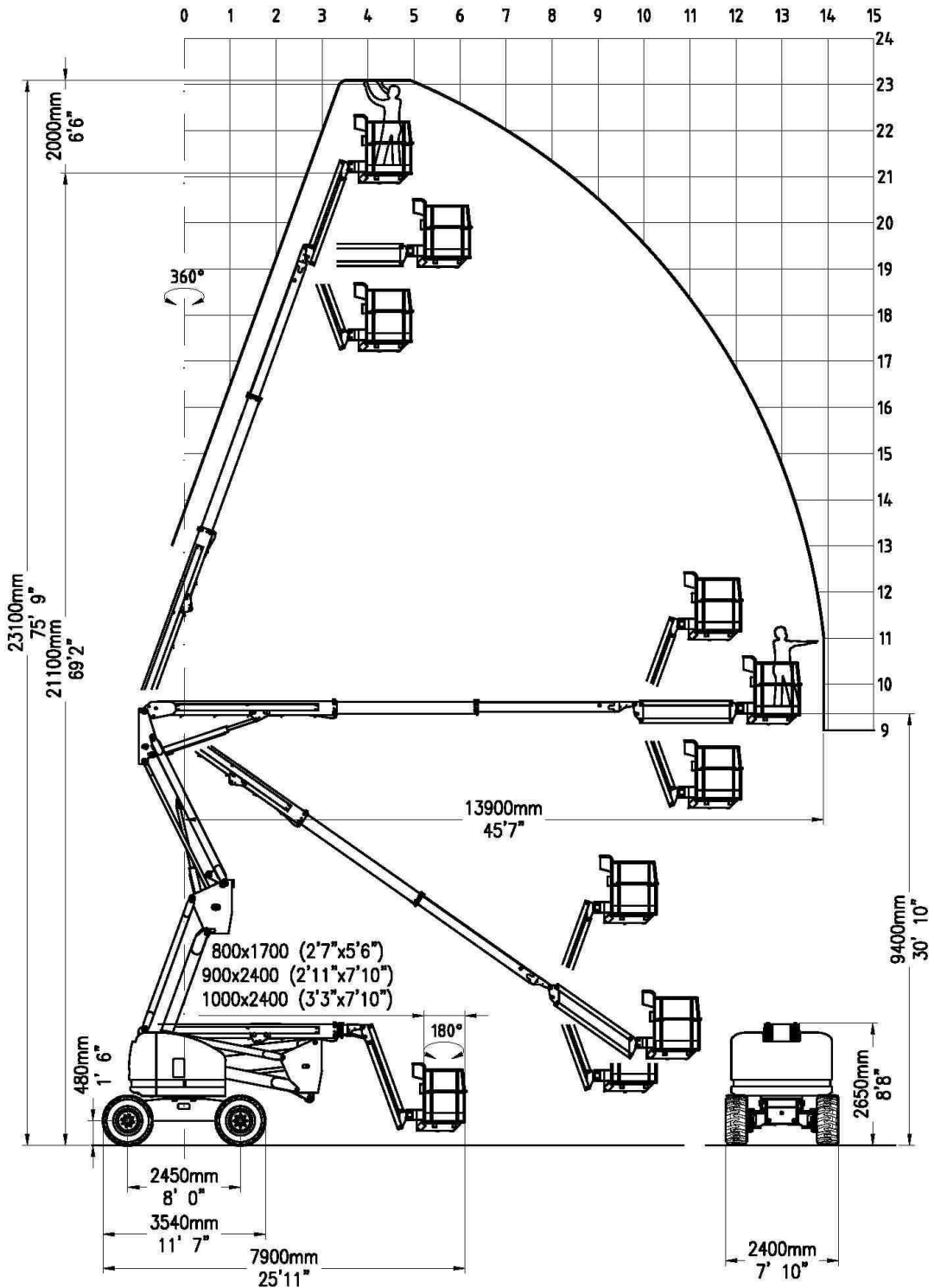
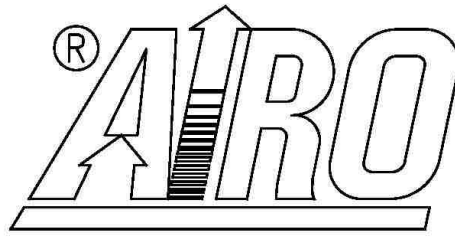

## 2.5. Vibrations and noise

Noise tests have been carried out under the most unfavourable conditions to study the effects on the operator. The level of acoustic pressure weighed (A) at work places does not exceed 70dB(A) for each electrical models.

For the Diesel engine models, the level of acoustic pressure weighed (A) at work places does not exceed 106dB(A), the level of acoustic pressure at ground control panel does not exceed 85dB(A), the level of acoustic pressure at platform control panel does not exceed 78bD(A).

As to vibrations in ordinary working conditions:

- The average weighted quadratic value in frequency of the acceleration which the upper members have to withstand is below **2.5 m/sec<sup>2</sup>** for each of the models to which this Use and Maintenance manual refers.
- The average weighted quadratic value in frequency of the acceleration which the body has to withstand is below **0.5 m/sec<sup>2</sup>** for each of the models to which this Use and Maintenance manual refers.

### 3. SAFETY PRECAUTIONS

#### 3.1. Personal protective equipment (PPE)

Always wear personal protective equipment according to current regulations concerning industrial health and safety (in particular, hard hat and safety shoes are **COMPULSORY**).

It is the operator or safety manager's responsibility to choose the personal protective equipment (PPE) depending on the activity to be carried out. For their correct use and maintenance, refer to the equipment manuals themselves.

The use of safety harness is not compulsory except in certain countries with specific regulations. In Italy, the consolidation act on safety, **Law Decree 81/08**, has made the use of a safety harness mandatory.

The harness is attached to one of the anchorages reported by labels, as in the following picture.

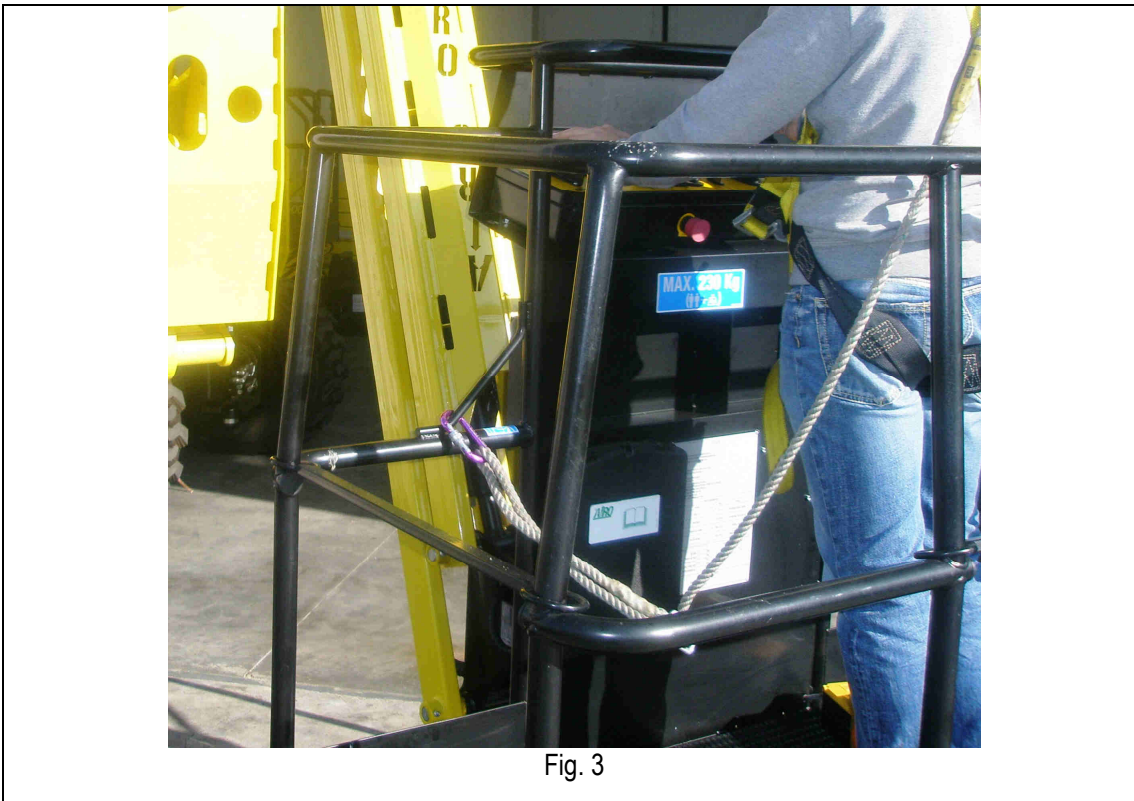

Fig. 3

#### 3.2. General safety norms



- Only adults (18 years old), after carefully reading this manual, are allowed to use the machine. The employer is responsible for training.
- The platform is intended for people carriage; therefore, comply with the current local regulations relevant to this class of machines (see chapter 1).
- At least two users must operate the machine, one of them on the ground, able to carry out the emergency operations described in this handbook.
- Always keep the machine at a safety distance from power lines as indicated in the next chapters.
- Use the machine according to the capacity values indicated in the technical features section. The identification plate shows the maximum number of people allowed on the platform at any one time, the maximum capacity and the tool and material weight : **Never exceed the indicated figures.**
- Do NOT use the framework of the platform or any of its elements for grounding connection while welding on platform.
- It is absolutely forbidden to load and/or unload persons and/or material with platform not in the access position.
- It is the machine owner and/or safety manager's responsibility to check that the maintenance and repair operations are carried out by skilled personnel.

### 3.3. Use instructions

#### 3.3.1. General

- The electric and hydraulic circuits are provided with safety devices, calibrated and sealed by the manufacturer:



**DO NOT TAMPER WITH AND MODIFY THE CALIBRATION OF ANY COMPONENT OF THE ELECTRIC AND HYDRAULIC SYSTEMS.**

- The machine must be used only in areas well lit up, checking that the ground is flat and firm. The machine may not be used if the lighting conditions are not sufficient. The machine is not equipped with any lightning system.
- Before using the machine check its integrity and conservation state.
- During maintenance operations do not dispose of any waste materials in the environment, but comply with current regulations.
- Do not carry out any service or maintenance operations when the machine is connected to the mains supply. Follow the instructions given in the following paragraphs.
- Do not approach the electric and hydraulic system components with sources of heat or flames.
- Do not increase the max. allowed height by means of scaffolds, ladders or other.
- With the machine lifted, do not fasten the platform to any structure (beams, pillars or wall).
- Do not use the machine as a crane, hoist or lift.
- Protect the machine (in particular the platform control panel by means of the specially provided cover- optional) and the operator when working in adverse environmental conditions (painting, de-painting, sand-blasting, washing, etc.).
- Using the machine in bad weather conditions is forbidden; in particular, wind speeds must not exceed the limits indicated in the technical specifications (to measure speeds, see following chapters).
- Machines with a wind speed limit of 0 m/s are to be used indoors only.
- In the event of rain or in parking condition always protect the platform control panel by means of the specially provided cap (optional).
- Do not use the machine in areas where risks of fire or explosion exist.
- Do not use pressurized water jets (high-pressure cleaners) to wash the machine.
- Overloading the work platform is forbidden.
- Avoid knocks and/or contacts with other vehicles and fixed structures.
- Leaving or accessing the work platform is forbidden unless this is in the position required for access or leaving (see the "Accessing the platform" chapter).



#### 3.3.2. Handling

- Before handling the machine check that the connection plugs are disconnected from the power supply source. Always check the cable position during handling if the machine is powered with a 230V electrical pump.
- In order to avoid any instability, use the machine on regular and firm grounds. To prevent the machine from overturning, comply with the max. gradeability values indicated in the Technical data section under paragraph "Stability limits". However, movements on inclined grounds are to be carried out with the utmost caution.
- As soon as the platform is lifted (the tolerance varies from model to model) the safety drive speed is automatically activated (all models of this handbook have passed the stability tests in compliance with standard EN280:2001 ).
- Drive the machine with lifted platform only on flat grounds, verifying the absence of holes or steps on the floor and bearing in mind the overall dimensions of the machine.
- While driving the machine with lifted platform the operators are not allowed to place horizontal loads onto the platform (operators on board must not pull ropes, wires, etc.).
- The machine must not be used directly for road transport. Do not use it for material transport (see paragraph "Intended use").





- Check that in the operating area there are not obstacles or other dangerous elements.
- Pay particular attention to the area above the machine during lifting to avoid any crushing and collisions.
- During operation keep your hands in safety position, the driver has to place them as shown in picture A or B while the transported operator has to keep them as shown in picture C.

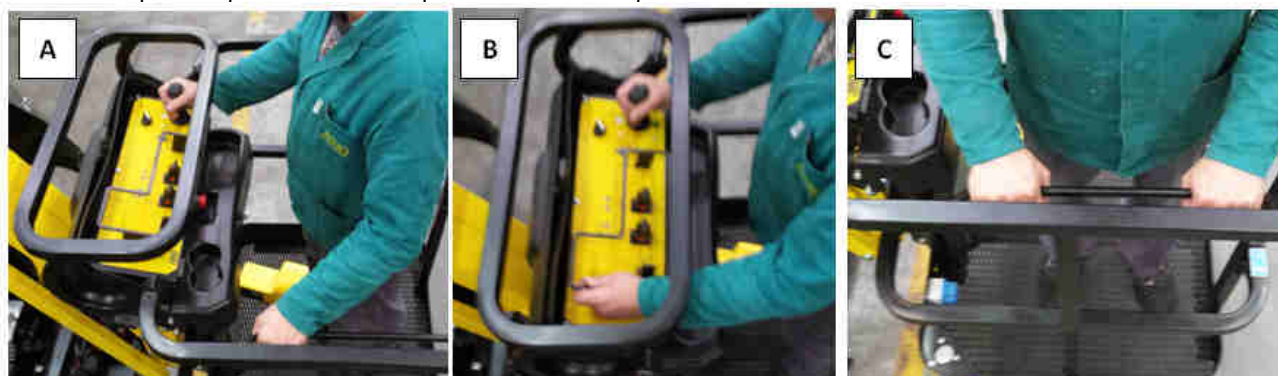



fig. 4

### 3.3.3. Operating procedures

- The machine is equipped with a chassis inclination control system disabling lifting operations in case of unstable positioning. Working operations can be resumed only after placing the machine in a steady position. If the audible alarm and the red light on the platform control panel turn on, the machine is not correctly positioned (see paragraphs relevant to "Use instructions"). It is necessary to bring it to safety rest position before starting operations again. If the tilt alarm trips with the platform elevated, the only possible operations are those that allow lowering the platform.
  - The machine is equipped with an overload controller stopping the platform in case of overloading. In case of platform overloading when lifted, also drive is disabled. Platform operation can be resumed only after removing the exceeding load. Should the audible alarm and the red light located on the platform control panel turn on, then the platform is overloaded (see chapter "Red warning light overload"). Remove the exceeding load before starting operations again.
- 
- Electric-powered machines are equipped with a device controlling the electric system isolation. In case of isolation loss or remote switch fault, such device (located on the chassis or on the turret – see paragraph "Location of main components") brings the machine to a complete halt and signals the fault by means of a continuous hissing sound.
  - Electrical-powered machines feature a device for checking the state of battery charge (battery protection): when battery charge is at 20% the operator on the platform is informed of this condition through a flashing red light. In this condition lifting is disabled, battery should be immediately charged.
  - Do not lean over the platform guard rails.
  - Make sure that no people, apart from the operator, are in the area where the machine is operating. While moving the platform, the operator on board should pay particular attention to avoid any contact with the personnel on the ground.
  - During operations in public areas, in order to prevent people other than the personnel from approaching the machine and being endangered, surround the working area by means of barriers or other suitable signs.
  - Avoid severe weather conditions and, in particular, windy days.
  - Lift the platform only if the machine is resting on solid and horizontal surfaces (following chapters).
  - Drive the machine with lifted platform only if the ground is solid and horizontal.
  - Do not use the thermic drive power (Diesel or Petrol motor) indoors or in insufficiently ventilated areas.
  - After each work session, always take the keys out of the control panels and keep them in a safe place to prevent unauthorized people from using the machine.
  - Always place working tools in a steady position to prevent them from falling and hurting the operators on the ground.

When choosing the positioning point of the chassis, to prevent unexpected possible contacts with obstacles, always observe the figures carefully as these make it possible to identify the range of action of the platform (chap. 2).

### 3.3.4 Wind speed according to Beaufort scale

You can use the table below for a simple assessment of the wind speed. We remember that the max. limit for each machine model is indicated in the table TECHNICAL FEATURES OF STANDARD MACHINES.



The machines for which the max. wind limit is 0 m/s must be used indoors only. These machines cannot be used outdoors even with no wind.

Beaufort Number	Wind speed (km/h)	Wind speed (m/s)	Description	Sea conditions	Land conditions
0	0	<0.28	Calm	Flat	Calm. Smoke rises vertically.
1	1-6	0.28-1.7	Light air	Ripples without crests.	Wind motion visible in smoke.
2	7-11	1.7-3	Light Breeze	Small wavelets. Crests of glassy appearance, not breaking.	Wind felt on exposed skin. Leaves rustle.
3	12-19	3-5.3	Gentle breeze	Large wavelets. Crests begin to break; scattered whitecaps.	Leaves and smaller twigs in constant motion.
4	20-29	5.3-8	Moderate breeze	Small waves.	Dust and loose paper raised. Small branches begin to move.
5	30-39	8.3-10.8	Fresh breeze	Moderate (1.2 m) longer waves. Some foam and spray.	Smaller trees sway.
6	40-50	10.8-13.9	Strong breeze	Large waves with foam crests and some spray.	Large branches in motion. Whistling heard in overhead wires. Umbrella use becomes difficult.
7	51-62	13.9-17.2	Near gale / moderate gale	Sea heaps up and foam begins to streak.	Whole trees in motion. Effort needed to walk against the wind.
8	63-75	17.2-20.9	Fresh gale	Moderately high waves with breaking crests forming spindrift. Streaks of foam.	Twigs broken from trees. Cars veer on road.
9	76-87	20.9-24.2	Strong gale	High waves (6-7 m) with dense foam. Wave crests start to roll over. Considerable spray.	Larger branches break off trees, construction/temporary signs and barricades blown over, damage to circus tents and canopies.
10	88-102	24.2-28.4	Whole gale / Storm	Very high waves. The sea surface is white and there is considerable tumbling. Visibility is reduced.	Trees broken off or uprooted, saplings bent and/or deformed, poorly attached asphalt shingles and shingles in poor condition peel off roofs.
11	103-117	28.4-32.5	Violent storm	Exceptionally high waves.	Widespread vegetation damage, minor damage to most roof shingles/surfaces, gravel may be blown from flat roofs.
12	>117	>32.5	Hurricane	Huge waves. Air filled with foam and spray. Sea completely white with driving spray. Visibility greatly reduced.	Considerable and widespread damage to vegetation, a few windows broken, structural damage to mobile homes and poorly constructed sheds and barns.

### 3.3.5 Pressure of the machine on ground and load-bearing capacity of ground

Before using the machine, the operator must make sure the floor is suitable for withstanding the specific loads and pressures on the ground with a certain safety margin.

The following chart provides the parameters in play and two examples of calculation of the average pressure on the ground below the machine and max pressure underneath the wheels or stabiliser outriggers (p1 and p2).

SYMBOL	U.M.	DESCRIPTION	EXPLANATION	FORMULA
P1	Kg	Total machine weight	It represents the weight of the machine, not including nominal load. Note: always refer to the details indicated on the plates affixed to the machine.	-
M	Kg	Nominal Load	The max. load allowed for the work platform.	-
A1	cm <sup>2</sup>	Area occupied on the ground	Machine supporting area on the ground determined by the result of TRACK x WHEEL BASE.	$A1 = c \times i$
c	cm	Track	Cross width of machine measured outside the wheels. or: Cross width of machine measured between levelling outrigger centres.	-
i	cm	Wheel base	Longitudinal length of machine measured between wheel centres. or: Longitudinal length of machine measured between outrigger centres.	-
A2	cm <sup>2</sup>	Wheel or levelling outrigger area	Wheel or levelling outrigger ground support area. The wheel support area on the ground must be verified empirically by the operator; the levelling outrigger support area depends on the shape of the support foot.	-
P2	Kg	Max. load on wheel or levelling outrigger	This represents the max. load that can be discharged onto the ground by a wheel or by a levelling outrigger when the machine is in the worst position and load conditions. Note: always refer to the details indicated on the plates affixed to the machine.	-
p1	Kg/cm <sup>2</sup>	Pressure on ground	Average pressure placed on the ground in idle conditions and supporting the nominal load.	$p1 = (P1 + M) / A1$
p2	Kg/cm <sup>2</sup>	Max specific pressure	Max. pressure which a wheel or a levelling outrigger can place on the ground when the machine is in the worst position and load conditions.	$p2 = P2 / A2$

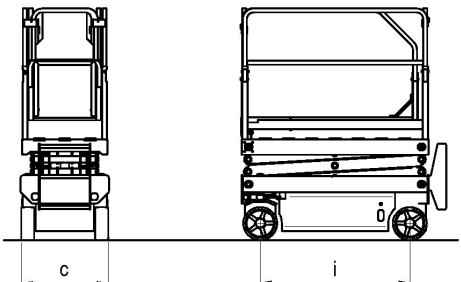

**EXAMPLE 1: SCISSOR LIFT**

P1 = 1395 kg  
P2 = 680 kg  
M = 250 kg  
c = 76,5 cm  
i = 132,0 cm  
A1 = c x i = 10098 cm<sup>2</sup>  
A2 = 71,5 cm<sup>2</sup>

$p1 = (P1+M)/A1 = 0,16 \text{ kg/cm}^2$   
 $p2 = P2/A2 = 9,5 \text{ kg/cm}^2$

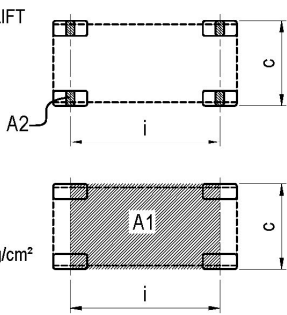

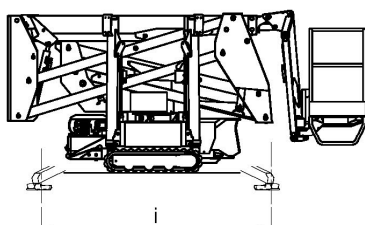

**EXAMPLE 1: CRAWLER LIFT**

P1 = 2200 kg  
P2 = 920 kg  
M = 200 kg  
c = 295 cm  
i = 295 cm  
A1 = c x i = 87025 cm<sup>2</sup>  
A2 = 62,8 cm<sup>2</sup>

$p1 = (P1+M)/A1 = 0,03 \text{ kg/cm}^2$   
 $p2 = P2/A2 = 14,6 \text{ kg/cm}^2$

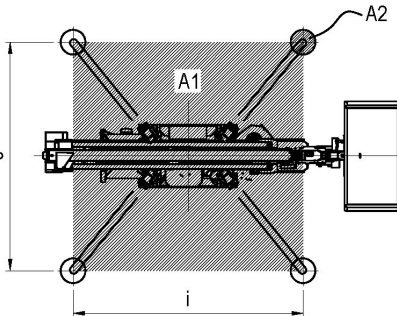

The table below shows the load-bearing capacity of the ground split up by ground type. Refer to the data contained in the specific tables of each model (chapter 2, TECHNICAL FEATURES OF STANDARD MACHINES) to obtain the figure relating to the max pressure on the ground caused by the single wheel.



**Using the machine is forbidden if the max pressure on the ground per wheel is above the load-bearing capacity of the specific type of ground on which the machine is to be used.**

TYPE OF GROUND	BEARING CAPACITY IN Kg/ cm <sup>2</sup>
Non compact filling earth	0 – 1
Mud, peat, etc.	0
Sand	1.5
Gravel	2
Friable earth	0
Soft earth	0.4
Rigid earth	1
Semi-solid earth	2
Solid earth	4
Rock	15 - 30

Should you have any doubts, verify the load-bearing capacity with specific tests. In case of constructed surfaces (concrete floors, bridges, etc.) the load-bearing capacity must be provided by the builder.

### 3.3.6 High-voltage power lines

The machine is not electrically insulated and is not protected in case of contact with or vicinity to power lines. A minimum distance must be kept from the power lines according to applicable laws and the following table

Type of power lines	Voltage (KV)	Minimum distance (m)
Light poles	<1	3
	1-10	3.5
	10 - 15	3.5
	15 - 132	5
	132 - 220	7
	220 - 380	7
High-voltage pylons	>380	15

### 3.4. Hazardous situations and/or accidents

- If, during Preliminary Operation Checks or when using the machine, the operator discovers a defect that could produce a hazardous situation, the machine must be placed in **safety condition** (isolate it and affix a notice) and the employer must be notified about the fault.
- If, during use, an accident occurs, with injury to the operators, caused by operating errors (e.g., collisions) or any structural yielding, the machine must be placed in **safety condition** (isolate it and affix a notice) and the employer must be notified about the fault.
- In case of an accident with injuries to one of more operators, the operator on the ground (or on a platform not involved in the accident) must:
  - **Seek help immediately.**
  - Perform the operation to return the platform to the ground **only if he is certain this will not make the situation worse.**
  - Place the machine in safety condition and notify the fault to the employer.

## 4. INSTALLATION AND PRELIMINARY CHECKS

The machine is supplied completely assembled, therefore it can perform all functions in full safety as provided for by the manufacturer. No preliminary operation is required. To unload the machine, follow the instructions in chapter "Handling and carrying".

Place the machine on a sturdy enough surface (see paragraph 3.3.5) and with a gradient below max. allowed gradient (see technical features "Stability limits").

### 4.1. Becoming acquainted with the machine

Anyone wishing to use a machine with weight, height, width and length characteristics or which generally differs significantly from the training received must be updated in order to cover the differences.

The employer shall be responsible for ensuring all the operators who use work equipment are adequately trained and in order with applicable health and safety legislation.

### 4.2. Preliminary operation checks

Before using the machine read the instructions given in this manual and the concise instructions indicated on the platform plate. Check the perfect integrity of the machine (by sight check) and read the plates showing machine operating limits.

Before using the machine the operator must always check visually that:

- Make sure the battery is fully charged and the fuel tank is full.
- The oil level lies between the min. and max. value (with lowered platform).
- The ground is sufficiently horizontal and solid.
- The machine carries out all operations in safety.
- The wheels and drive motors are properly fixed.
- The wheels are in good condition.
- Make sure the rails are fastened to the platform and the gate/s are in automatic reclosing mode.
- The structure does not show clear faults (visually check welding of lifting structure).
- The instructions plates are perfectly readable.
- The platform control panel and the ground emergency control panel, dead-man system included, are perfectly efficient.
- The anchoring points for the harness are in perfect state of conservation.

Do not use the machine for purposes different from those it was intended for.

## 5. HOW TO USE

Before using the machine read this chapter thoroughly.



### WARNING!

Follow exclusively the instructions given in the next paragraphs and the safety rules described both hereafter and in the previous paragraphs. Read the next paragraphs carefully in order to properly understand the on/off procedures as well as all operations and their correct use.

### 5.1. Platform control panel

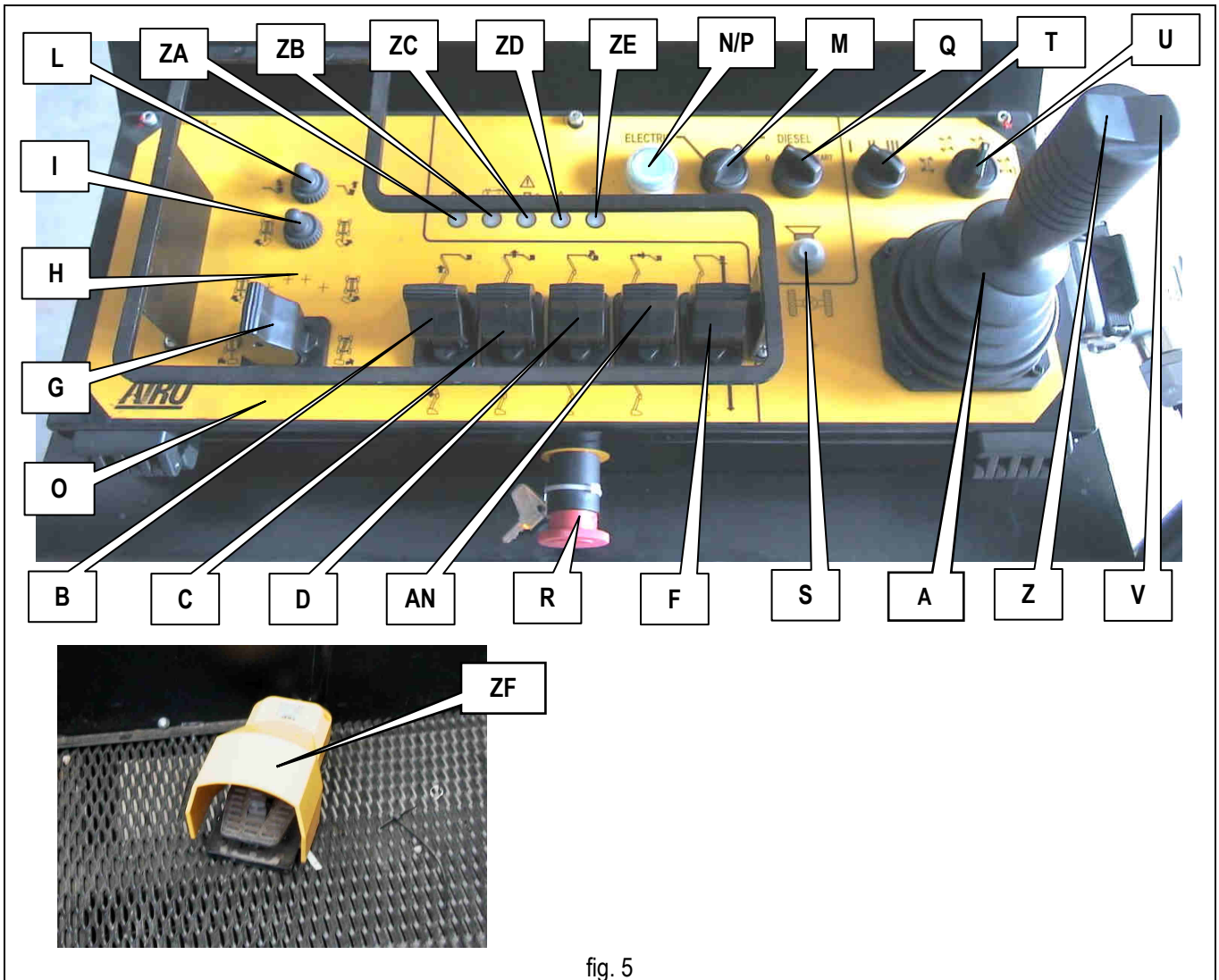

fig. 5

- A) Drive proportional joystick control
- B) Proportional lever control pantograph up/down
- C) Proportional lever control boom up/down
- D) Proportional lever control jib up/down
- E) Proportional lever control telescopic boom out/in
- F) Proportional lever control QUICK UP/QUICK DOWN (fast lifting/lowering)
- G) Proportional lever control turret rotation
- H) Proportional lever control jib rotation - OPTIONAL
- I) Platform rotation switch
- L) Platform level switch

- M Power selector: Diesel/Electrical or Electrical DC (48Vdc battery)/Electrical AC (mains)
- N) Electric power selector 12V (Battery) or 380V (three-phase mains) – if both installed –
- O) Starter button electrical pump 12V (Battery) or 380V (three-phase mains) – if both installed –
- P) Electrical pump starter button 12V (Battery) or 380V (three-phase mains) – if individually installed –
- Q) Diesel engine start button
- R) Emergency brake (STOP)
- S) Manual horn
- T) Drive speed selector
- U) Rear wheels alignment control and steering mode selector - OPTIONAL
- V) Right steering switch
- Z) Left steering switch
- ZA) Enabled control panel warning light
- ZB) Flat battery red warning light – models – E
- ZC) Diesel engine fault / low fuel level warning light – models – D
- ZD) Danger warning light
- ZE) Overload warning light
- ZF) Dead-man pedal

All movements (except for platform rotation and platform level compensation) are controlled by proportional joystick /levers; it is therefore possible to adjust movement speed by means of the relative controls. To avoid sudden shakes during movements, it is advisable to operate the proportional joystick controls gradually.

For safety reasons, to operate the machine, it is necessary to press the platform dead-man pedal **ZF**. If the dead-man pedal is accidentally released while the machine is operating, the movement is immediately stopped.



**WARNING!**

**Holding down the dead-man pedal for over 10 seconds without carrying out any operation will disable the control panel.**

**The control panel disabled condition is indicated by the flashing green led (ZA). To operate the machine again it is necessary to release the circuit-breaker and press it again; the green led (ZA) will light up steady and for the next 10 seconds all controls will be enabled.**



### 5.1.1. Drive and steering



Before carrying out any displacement operation, verify that no people are in proximity of the machine and in any case proceed with the utmost caution.



**IT IS FORBIDDEN to drive the machine when the platform is lifted unless the chassis is flat and steady with no holes and steps.**

To drive the machine carry out the following operations in sequence:

- Press dead-man pedal **ZF** located on the platform; the green led **ZE** will light up steady indicating its enabling.
- Within 10 seconds from the green steady led lighting up, set the proportional joystick control **A** forward for forward drive or backward for reverse drive.

The machine can be equipped with an automatic reverse device of drive and steering; whatever the turret position might be, the operator at the platform control panel will always face the front of the machine.



**WARNING!! Beware the position of the turret orientated at +/-90° with respect to the direction of drive since this position causes the automatic reversal of drive and steering.**

Drive and steering controls can take place at the same time but they are interlocked with the platform movement controls (lifting/lowering/rotation). With platform lowered (booms down, telescopic boom in, jib at a height between +10° and -70°) simultaneous steering-drive-turret rotation is possible to facilitate the machine positioning in narrow spaces.

**By simultaneously controlling drive/steering and turret rotation, the drive/steering reversal takes place- only past the +/-90° turret position- after releasing the present drive/steering controls.**

With platform lowered (booms down, telescopic boom in, jib at a height between +10° and -70°) it is possible to select different drive speeds by means of the speed selector T.

NOTE: To achieve maximum drive speed, set the speed selector (T) to position (III), and press down the proportional joystick (A).  
To operate on high ascending slopes (e.g. while loading the machine onto a truck) set the speed selector (T) to position (II).  
To operate on high descending slopes (e.g. while unloading the machine from a truck) and get the minimum speed with lowered platform, set the speed selector (T) to position (I).

With platform lifted the safety drive speed and steering mode (two front steering wheels) are automatically activated.



**WARNING!! The machine is equipped with a monitoring sensor for drive pressure. This device cuts off the drive control (the machine stops temporarily) if the required power is higher than the one provided by the engine. To avoid the continuous intervention of the limiting device, it is recommended not to use the III drive speed with cold oil. The ideal oil temperature for a correct operation of the machine ranges between 50°C and 65°C. Operate with the machine for 5-10 minutes before controlling drive in III speed.**



**NOTE FOR MACHINES WITH 4 STEERING WHEELS:**

If the steering mode with four discordant wheels has been selected (lower turning radius) the III drive speed is not enabled.



**NOTE FOR MACHINES WITH OSCILLATING AXLE:**

A sensor controls the swinging of the oscillating axle. With platform raised (booms up and jib at a height over +10° with respect to the horizontal axis) if the wheels of the oscillating axle are not on the same ideal plane as those of the fixed axle (with some tolerance) drive is prevented and a red light will turn on to warn of this condition (ZC). The danger alarm will not go off. To drive the machine lower the platform (booms down and Jib at a height between +10° and -70°).

To steer, press the buttons **V / Z** located on the drive proportional joystick control (press the right button for right steering and vice versa). Also the steering control is enabled by the “dead-man” pedal and it is possible only if the green led **ZE** is lit up steady.

For machines equipped with 4 steering wheels you can select three steering modes:

- Two front steering wheels.
- Four concordant steering wheels (the four wheels steer in the same direction and allow the machine to move sideways with respect to the chassis).
- Four discordant steering wheels (the four wheels steer differently between the front axle and the rear axle, and allow the machine to steer in narrow spaces).

**With platform lifted the safety drive speed is automatically activated.**



**NOTE FOR MACHINES WITH 4 STEERING WHEELS:**

With platform lowered (booms down, telescopic boom in and Jib at a height between +10° and -70°) if the steering mode with four discordant wheels has been selected (lower turning radius) the III drive speed is not enabled.

### 5.1.2. Platform Positioning Movements

To carry out all movements other than drive, use proportional levers **B, C, D, E, F, G, H** and switches **I** and **L**.

To achieve the movement it is necessary to carry out the following operations in sequence:

- a) Press dead-man pedal located on the platform; the green led **ZE** will light up steady indicating its enabling.
- b) Within 10 seconds from the green steady led lighting up set the proportional joystick control or the desired switch in the direction shown by the serigraphy on the control panel.

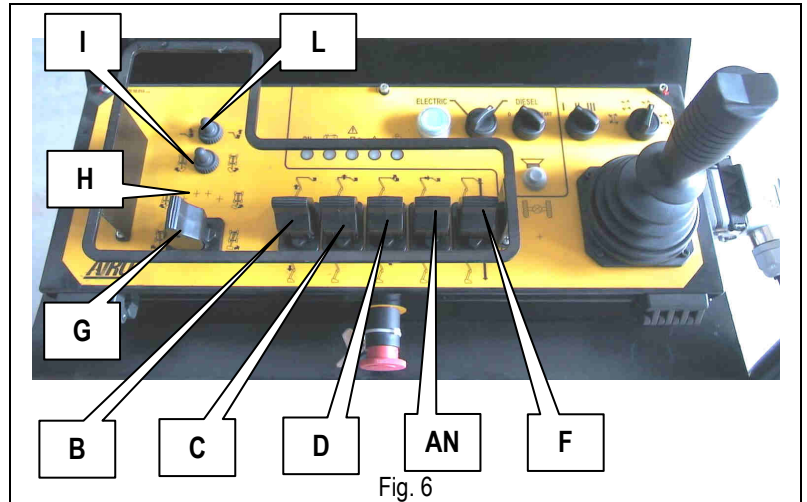

Fig. 6

**NOTE:** before activating the proportional joystick control or the desired switch the dead-man pedal must be pressed. Release the dead-man pedal and the manoeuvre will be immediately stopped.



In both versions (electric 4 wheel drive "RTE", and diesel 4 wheel drive "RTD") the platform positioning controls can be used simultaneously (unless otherwise indicated). Furthermore, the turret orientation can be operated at the same time as the drive and steering controls in lowered platform conditions (arms lowered, telescopic boom closed, jib at a height between +10° and -70°).

#### 5.1.2.1. Pantograph (lower boom) lifting/lowering

To lift/lower the pantograph (lower boom), use the proportional lever **B**. Set the proportional lever **B** forward for lifting or backward for lowering.



In the event of any interference between the pantograph and the boom while lowering, a special microswitch will block the manoeuvre of "pantograph lowering" and "secondary boom lowering".

#### 5.1.2.2. Upper boom lifting/lowering

To lift/lower the upper boom, use the proportional lever **C**. Set the proportional lever **C** forward for lifting or backward for lowering.



In the event of any interference between the pantograph and the boom while lowering, a special microswitch will block the manoeuvre of "pantograph lowering" and "secondary boom lowering".

#### 5.1.2.3. Jib lifting/lowering

To lift/lower the JIB, use the proportional lever **D**. Set the proportional lever **D** forward for lifting or backward for lowering.

#### 5.1.2.4. Telescopic boom extension/retraction

To extend/retract the telescopic boom, use the proportional lever **E**.  
Set the proportional lever **E** forward for extension or backward for retraction.



**This manoeuvre does not work while turret rotation is taking place.**

#### 5.1.2.5. QUICK UP/QUICK DOWN (OPTIONAL)

This lever controls the quick lifting/lowering of the platform, while simultaneously controlling the following manoeuvres:

- Pantograph lifting/lowering.
- Secondary boom lifting/lowering.
- Jib lifting/lowering.
- Telescopic boom extraction/retraction (DIESEL MODELS ONLY).

To carry out the QUICK UP/QUICK DOWN manoeuvre, use the proportional lever **F**.  
Set the proportional lever **F** forward for quick lifting or backward for lowering.



**In the event of any interference between the pantograph and the boom while lowering, a special microswitch will block the manoeuvre of "pantograph lowering" and "secondary boom lowering".**

#### 5.1.2.6. Turret orientation (rotation)

To carry out the turret orientation manoeuvre (rotation), use the proportional lever **G**.  
Set the proportional lever **G** to the right for right rotation or to the left for left rotation.



**Before carrying out this manoeuvre make sure that the mechanical lock device of the turret - if any - be deactivated (see chapter 6 "handling and carrying").**

**This manoeuvre does not work while the telescopic boom extraction/retraction is taking place.**

**With platform lowered (booms down, telescopic boom in, jib at a height between +10° and -70°) simultaneous steering-drive-turret rotation is possible to facilitate the machine positioning in narrow spaces.**

#### 5.1.2.7. Jib rotation (OPTIONAL)

To rotate the JIB, use the proportional lever **H**.  
Set the proportional lever **H** to the right for right rotation or to the left for left rotation.

### 5.1.2.8. Platform rotation

To rotate the platform, use the switch I.  
Set the switch I on the right for right rotation, or on the left for left rotation.



**This manoeuvre cannot be carried out when other operations are taking place.**

### 5.1.2.9. Platform levelling

The platform is automatically levelled. Should it be necessary to reset the correct level, use switch L.  
Set switch L backward for backward levelling or forward for forward levelling.



**Warning!! This operation can be carried out only when booms are completely lowered. No result is achieved if these operations are carried out when the platform is lifted.**

**This manoeuvre cannot be carried out when other operations are taking place.**

### 5.1.3. Other functions of the platform control panel

#### 5.1.3.1. Electric/thermic power selection, electrical ac/electrical dc

On a few models the type of power can be selected using the selector **M**.

On models equipped with heat engine, set it to **Electric** position to use the electric power (12V battery for boom emergency operations or 380V three-phase for boom work operations - OPTIONAL); set it to **Diesel** position to use the thermic power.

In models with 48Vdc battery electric power, by rotating in **ELECTRIC AC** position it is used the 380V three phase electric power by pump -OPTIONAL-; by rotating in **ELECTRIC DC** position it is used the 48Vdc battery electric power.

#### 5.1.3.2. Electric power selector 12V (Battery) or 230V/380V three-phase (power mains) - (OPTIONAL)

On models equipped with heat engine, once the electric power has been selected by means of selector **M**, it is possible to select the type of power using the selector **N** (if both electric pumps installed):

- Set it to position **12V** to enable the power for emergency operations (lifting/lowering and rotation only) through the 12V electric pump which is directly powered by the starting batteries of the heat engine;
- Set it to position **380V** to enable the power through the 380V three-phase electric pump for platform work operations (lifting/lowering/rotation).



**WARNING! The power by the 12V emergency electrical pump is only for platform lowering in case of faults in the main powers. Do not use it during normal work operations.**

#### 5.1.3.3. Electrical pump start button 12V (Battery) or 230V/380V three-phase mains (power mains) - (OPTIONAL)

Push-button **P** (instead of selector **N**, if only the 12Vdc or the 380Vac electric pump is installed) is for starting the electric pump. The 12V electric pump is usable only for emergency operations (excluding drive and steering).

Use button **O** (if both electric pumps are installed) to start:

- the 380V three-phase for platform movement (excepting drive and steering) if selector **N** is set to position 380V and the ground electric panel is connected to three-phase electric mains.
- the 12V electric pump for emergency operations (excepting drive and steering) if selector **N** is set to position 12V;

See next paragraphs for operations modes of the start button of the electrical pump.

#### 5.1.3.4. Three-phase 380V electric pump warning light lit up

The led near the ON/OFF button (**O** or **P** depending on the options installed) of the three-phase 380V electric pump for the platform movement (drive and steering excluded) indicates that it is on.

This occurs when the ground control panel is connected to the three-phase electrical mains and:

- If the selector **N** is in position **380V**, in case of presence of both electric pumps to 12V and 380V on models with heat engine.
- If the selector **M** is in position **ELECTRIC AC**, in case of presence of a 380V electric pump on models with 48Vdc battery power.

#### 5.1.3.5. Heat engine start switch ( “ED”, “D” models)

It starts the heat engine (Diesel) on dual propulsion models (“ED”) and on thermic propulsion models (“D”).

With selector **M** in position **Diesel** operating the switch **Q**:

- In **START** position it enables starting.
- In position **3 sec** it pre-heats the plugs (motors with plugs only).
- in position **0** it stops the heat engine.

### 5.1.3.6. Manual horn

The horn warns that the machine is moving; press button **S** to activate it.

### 5.1.3.7. Emergency stop button

By pressing the red emergency STOP **R** button all control functions are stopped. Normal functions are enabled by rotating the button of 1/4 turn clockwise.

### 5.1.3.8. Warning lights

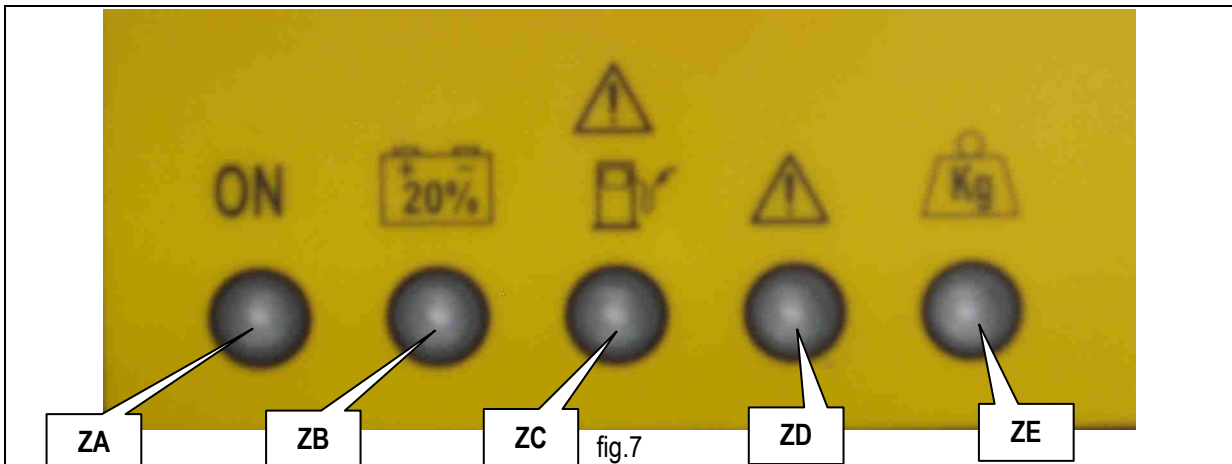

#### 5.1.3.8.1. Enabled control panel green warning light (ZA)

On with flashing light when the machine is turned on. If the platform control panel has been selected and this light flashes the controls are not enabled because the dead-man pedal is not pressed or it was pressed for more than 10 seconds and no operation was performed.

On steady with machine on and dead-man pedal pressed for less than 10 seconds. With platform control panel all controls are enabled (unless other types of warning show up – see next paragraphs).

#### 5.1.3.8.2. Flat battery red warning light (ZB) – electric models only

Flashing when the battery charge is at 20% (only models "E" or "ED" with current continuous electrical pump). In this condition lifting and telescopic boom extension are disabled. Batteries should be immediately recharged.

#### 5.1.3.8.3. Diesel engine fault / low fuel red warning light (ZC)

This warning light indicates malfunctioning of diesel engine or low fuel.

On steady with machine on; platform control panel; Diesel drive power selected. Diesel Engine off ready for start-up. Insufficient motor oil pressure.

Slow flashing in the event of the engine head overheating. If on, it stops the Diesel motor; if off, it prevents the Diesel motor from starting.

Fast flashing in the event of low fuel (approx. 10 litres of fuel left). This warning is active only when the motor is running.

#### 5.1.3.8.4. Danger red warning light (ZD)

It flashes quickly for 4 seconds together with the audible alarm at the machine start-up in case of fault during safety test on controls (pedal, joystick control, switches, etc).

It flashes with a series of three flashes when the chains of extraction and/or retraction are slackened or faulty ( A23 J ONLY). If the platform is lifted, extraction and retraction of the telescopic boom are stopped, but all other functions are still possible to allow the platform to lower to the ground. With lowered platform, lifting of boom and pantograph and telescopic extraction and retraction are stopped, but jib lifting and lowering remain active.

It is lit up steady when the chassis inclination exceeds the allowed value. All lifting operations and telescopic extension are disabled (except JIB lifting). If the machine is lifted, the audible alarm is activated and drive disabled. It is necessary to lower the booms completely and then place the machine onto a flat surface.

Lit up steady with no activation of the alarm when, with lifted platform, drive is blocked due to:

- Oscillating axle not parallel to the chassis.



**WARNING! The activation of this indicator warns of a dangerous situation since the machine has reached a dangerous inclination level for the machine stability.**

**When the chassis inclination exceeds the allowed value, to prevent increasing the overturn risk, the operator on the platform is recommended to retract the telescopic boom first and to lower it as the last operation.**

**If the pantograph is lifted and the telescopic boom is lowered and the latter interferes with the former, the system allows a gradual lifting of the boom, the consequent lowering of the pantograph and finally the total lowering of the platform.**

#### 5.1.3.8.5. Overload red warning light (ZE)

Lit up flashing with activation of audible alarm with a platform overload exceeding 20% the nominal load. If platform is lifted, the machine is completely locked. If the platform is lowered all driving/steering operations are still possible but lifting/rotation are disabled. Remove the overload before using the machine again.

Fast flashing in case of fault in the overload controller. With lifted platform the machine is completely locked. After reading the manual instructions, trained staff can carry out an emergency manoeuvre for platform lowering.



**WARNING! The activation of this indicator is a synonym of danger since the load at platform is exceeding or no overload controller is active upon signalling.**

**For adjustment or activation in emergency situations read the MAINTENANCE chapter.**



## 5.2. Ground control panel (electric control unit)

The ground control panel (or electric control unit) contains the main electronic boards necessary to operate the machine and to carry out safety checks.

The ground control panel is located on the rotating turret (see paragraph "Location of main components") and is used to:

- Turn the machine ON/OFF.
- Select the control panel (ground or platform).
- Operate the platform in emergency cases.
- Display some operation parameters (working hours; Diesel engine operational faults; battery charger operation; etc.).



**IT IS FORBIDDEN**  
**To use the ground control panel as a workstation when personnel is on the platform.**



Use the ground control panel only to start/stop the machine, to select the control panel or in emergency situations to allow the platform to be recovered.



Give the key to authorized persons and keep a duplicate in a safe place.  
 Always remove the on/off key at the end of work shifts.



Access to the electric control unit is allowed to specialized personnel only for maintenance and/or repair purposes. Access the electric control unit only after the machine has been disconnected from any 230V or 380V power sources.

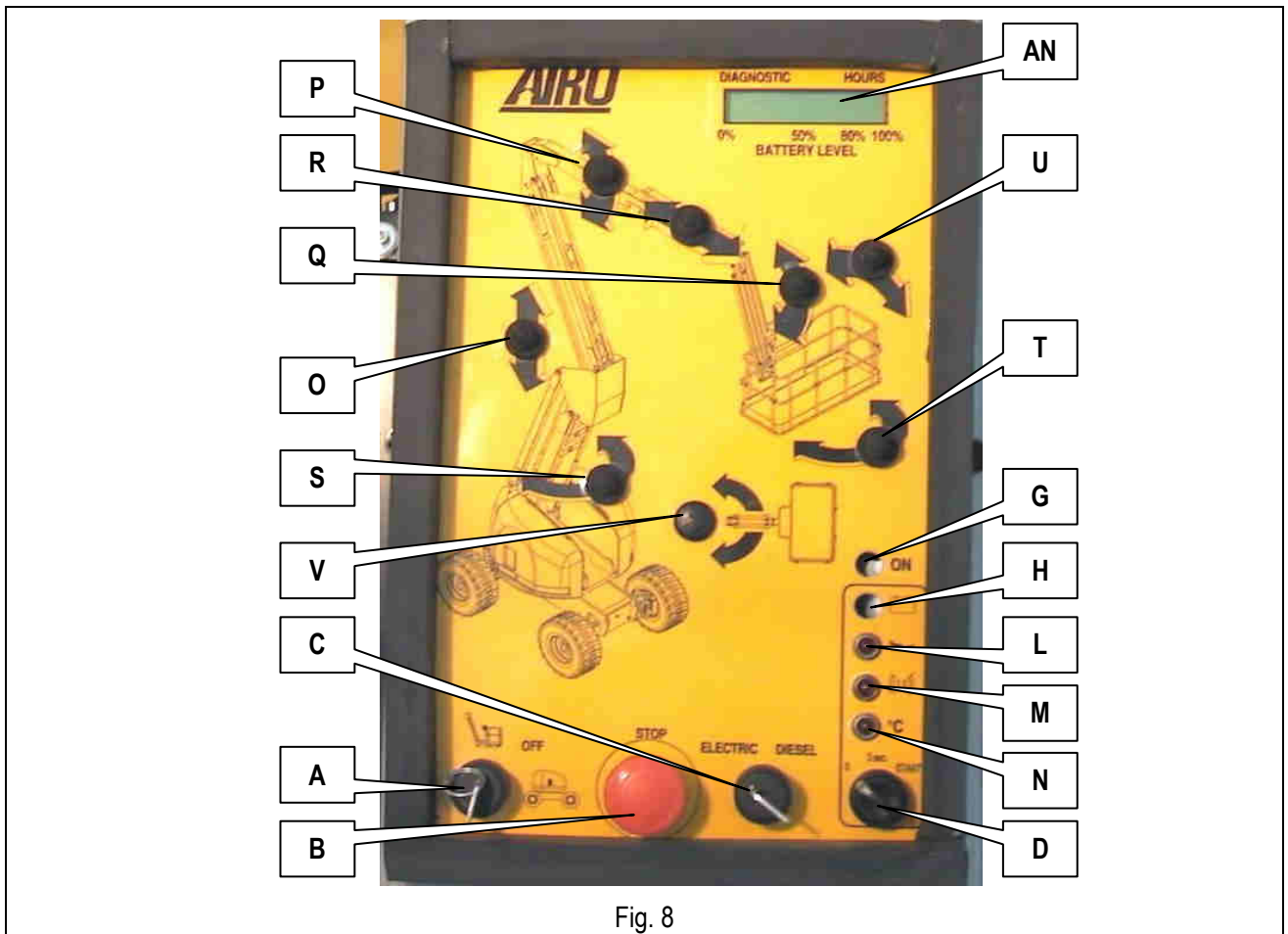

Fig. 8

- A) ON-OFF key and ground/platform control panel selector
- B) Emergency STOP button
- C) Selector for Diesel power for work or 12V electric power for emergency operations
- D) Heat engine start button (models "D" and "ED")
- E) User interface display
- F) Battery charger warning light (models "E" and "ED")
- G) Powered-on machine warning light
- H) Alternator warning light (models "D" and "ED")
- L) Oil warning light (models "D" and "ED")
- M) Air filter warning light (models "D" and "ED")
- N) Motor head temperature warning light (models "D" and "ED")
- O) PANTOGRAPH LIFTING/LOWERING lever
- P) BOOM LIFTING/LOWERING lever
- Q) JIB LIFTING/LOWERING lever
- R) TELESCOPIC BOOM OUT/IN lever
- S) TURRET ROTATION lever
- T) PLATFORM ROTATION lever
- U) PLATFORM LEVEL compensation lever
- V) JIB ROTATION lever (OPTIONAL)

### 5.2.1. On-off key and control panel selector (A)

The on-off key located on the ground control panel is used to:

- Turn ON the machine by selecting one of the two control panels:
  - Platform control panel enabled with locking key switch set to platform symbol. Stable key position with possibility to extract the key.
  - Ground control panel enabled (for emergency operations) with locking key switch set to turret symbol. Position with action to be kept. When the key is released the machine is turned off.
- Turn OFF the control circuits by turning it to OFF.

### 5.2.2. Emergency stop button (B)

By pressing this button the machine (as well as the heat engine on models "D", "ED" and "EB") is completely stopped; by rotating it of 1/4 turn (clockwise) the machine can be turned ON by means of the ON-OFF key.

### 5.2.3. Diesel/electric drive power selector (C)

Holding the ON-OFF key in position "ground control panel" it is possible to select the type of power for the ground controls:

- If ELECTRIC is selected and the on/off key is kept active in position "ground control panel" the 12V electric pump is started for the emergency controls or the 48V electric pump for "ED" models.
- If DIESEL is selected and the ON-OFF key is kept active in position "ground control panel" the Diesel engine can be started.

### 5.2.4. Heat motor start button (D)

Holding the ON-OFF key in position "ground control panel" after selecting the DIESEL power, the diesel engine can be started by means of the relevant switch.

- In "0" position the Diesel engine is off.
- In "3 sec" position the plugs pre-heating takes place (only for engines with plugs).
- In "Start" position the motor starts.

### 5.2.5. User interface display (E)

The multifunction display for machine/user interface is used to:

- Display the operation parameters of the machine during normal functioning or in the event of a fault.
- Working hours of Diesel engine (when Diesel power is selected the working hours are displayed in the format HOURS: MINUTES and final letter D).
- Working hours of the emergency electrical pump with continuous current (when 12V electrical power is selected the working hours are displayed in the format HOURS: MINUTES and final letter M).
- Working hours of the three-phase work pump (when 380V electric power is selected – at platform – the working hours are displayed in the format HOURS:MINUTES and final letter E).
- Charge level of the battery (only electrical models E).



**The user interface display is also used during any interventions by specialized personnel to adjust the working parameters of the machine. This function is not available to the user.**

### 5.2.6. Battery charger warning light (F)

Electric- and dual-powered models (“E”, “ED” and “EB”), equipped with a built-in high frequency battery charger, are provided with this warning light indicating the operation of the battery charger (for more detailed information read the paragraph “Battery charge”).

### 5.2.7. Enabled control panel warning light (G)

The green light is ON when the machine is turned ON and the ground control panel is enabled (the on/off key (C) should be kept in “turret” position).

### 5.2.8. Diesel engine warning lights (H L M N)

These warning lights warn the user of any Diesel motor operational faults (models “D” and “ED”). One of these warning lights turns ON when the motor is stopped. A “fault” message is sent to the operator on the platform (see paragraph “Platform control panel”). Once the Diesel motor has stopped due to a problem signalled by one of these warning lights, the motor can no longer be re-started until such problem has been solved.

### 5.2.9. Platform control levers

The various levers shown in the figure allow the platform to be operated. According to the various signs the corresponding movements are activated. These controls can be operated only if the on-off key is set to ON down (ground control panel selected). We shall also remind you that the ground controls are to be used to operate the platform only in emergency situations and must not be used for any other purposes.



**Use the ground controls only in emergency situations to allow the platform to be lowered.  
IT IS FORBIDDEN to use the ground control panel as a workstation when personnel is on the platform.**

### 5.3. Platform access

The “access position” is the only one from which loading or unloading of persons and materials is allowed. The “access position” to the work platform is the completely lowered configuration.

To get on the platform:

- Get on the platform hanging on to the entry guard rails.
- Raise the bar and get on board.

Check that, once you are on the platform, the bar falls down closing the access. Fasten the safety harness to the provided hooks.



**To get on the platform use only the access equipment the platform is provided with.**  
**When moving up or down, always keep your eyes on the machine and hold onto the entry stringers.**



**IT IS FORBIDDEN**  
**To lock the closing bar so as to keep the platform access door open.**



**IT IS FORBIDDEN**  
**Leaving or accessing the work platform if this is not in the position required for accessing or leaving is forbidden.**



Fig. 9

With the ground control panel (see paragraph “Ground control panel”) it is possible, operating the boom, to lower the height of access to the platform for a better access to the platform itself.

### 5.4. Machine start-up

To start the machine the operator shall:

- release the emergency stop button on the ground control panel by rotating it of 1/4 turn clockwise.
- turn the on-off key on the ground control panel to “Platform” position.
- remove the starting key and hand it over to a person in charge on ground, properly informed of the use of the emergency controls.
- get onto the platform.
- release the emergency stop button on the platform control panel by rotating it by 1/4 clockwise (see previous paragraphs).

**For electric propulsion machines** (models “E”), at this point the various functions can be performed by thoroughly following the instructions given in the previous paragraphs. To turn on the machine, the battery charger must be disconnected from the mains. If the battery charger is working, the machine is off and cannot be turned on.

**On dual propulsion models (Electric/Diesel)** (models “ED” or “EB”), it is necessary to select the power supply type by means of the selector. To use the electric drive power once this option has been selected the operator can start performing the various functions by following the instructions given in the previous paragraphs. To use the thermic drive power read the next paragraphs to start the heat engine.

**For Diesel propulsion machines (models “D”):**

- To use Diesel power select the power type “Diesel” with the selector and then read the next paragraphs to start the heat engine.
- To use the 230V or 380V electric power (optional) select the power type “Electric” with the selector and then (if available) the 230V or “380V” voltage (read the next paragraphs to start the three-phase electric engine).
- To use the 12V electric power (optional) (only for emergency controls) select the power type “Electric” with the selector and then (if available) the “12V” voltage and read the next paragraphs to start the 12V electric engine.

Before using the thermic propulsion (Diesel or Petrol motor) check the fuel level in the tank.

For those machines that are not equipped with a level gauge on the platform control panel, this operation should be carried out by visually checking the fuel level after unscrewing the filling cap; for the other machines it is possible to check the level directly through the level gauge on the platform control panel.

Before starting the working session, when the motor is off and sufficiently cool, visually check the fuel level. Keep the fuel tank and the motor clean.

For petrol motors (models “EB”) use only **Unleaded Petrol with Octane No. >87**.

### 5.4.1. Diesel engine start-up

By turning the starter key on the platform control panel:

- To “0” position the Diesel engine stops (models “D” and “ED”).
- To “3 sec” position the plugs pre-heating takes place (only engines with plugs) (models “D” and “ED”).
- In “Start” position the motor starts.



**Do not insist on the starting position for longer than 3 seconds. In the event of failed start, check the fuel level by means of the relevant indicator and read the Use and maintenance manual of the Engine.**

**Do not try to start the motor if it is already running. This operation may cause the pinion of the starter to break (under normal conditions the control system blocks this operation). In the event of operational faults, check the motor warning lights and read the Use and Maintenance manual of the motor.**

**NOTE: The Diesel engine can be started only if the dead-man pedal is neither pressed nor enabled. This means that the motor can be started only if the platform green warning light ON is flashing.**

## 5.4.2. Start-up of 380V work electrical pump (OPTIONAL)

Both Diesel-powered and 48Vdc battery powered models can be equipped, on request, with a 380V three-phase electric pump for the operations of the booms (lifting, lowering, rotation).

To start the three-phase electrical pump:

- Insert the 380 V plug of the power cable into socket (A) on the chassis.
- Set the switches (C) shown in figure to ON position.
- Set the angular red switch (F) to ON position turning it downwards or upwards. If the connection has been successfully carried out it is possible to start the electrical pump as indicated in next paragraphs. On the contrary, in the event of a phase fault in the electric power the audible alarm is automatically enabled, and the electrical pump cannot be started. In this case it is possible to compensate the power phases by turning the angular red switch (F) on the electric case by 90°.
- To start the electric pump with the platform controls:
  - Select the platform control panel with the locking key switch on the ground control unit.
  - Unlock the emergency stop button (D) turning by a ¼ of turn clockwise.
  - Set the power selector (B) to "Electric" position, in the case of models with Diesel engine, or "Electric AC", in the case of 48VDC battery models.
  - Select the 380V power, with the selector (E) in the case of simultaneous presence of 12Vdc electric pump.
  - Press the green button (H in the case of simultaneous presence of 12Vdc electric pump, or G).
  - The green light lit up (I, located close to H, in the case of simultaneous presence of 12Vdc electric pump, or G) indicates that the three-phase electric pump is switched on.
  - Wait 5 seconds before moving the machine.
- To switch off the electric pump, press the green button again (H in the case of simultaneous presence of 12Vdc electric pump, or G).

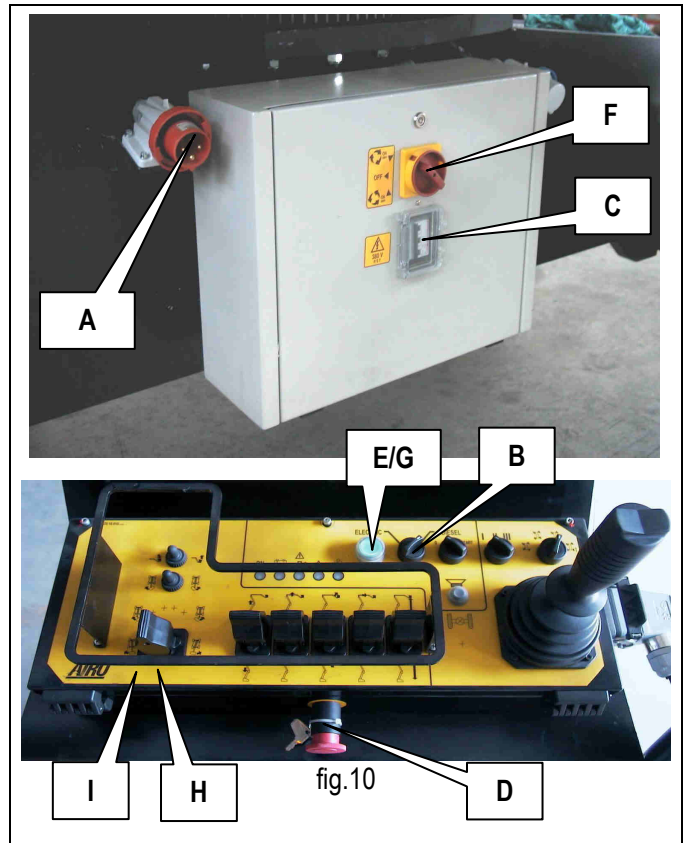

**N.B.** when the machine is powered with 380V electrical pump only platform positioning and not drive/steering can be performed. The operations carried out with 380V electrical pump are slightly slower than those with diesel engine.



**NOTE:** The electrical pump can be started only if the dead-man pedal is neither pressed nor enabled. This means that the electrical pump can be started only if the platform green warning light ON is flashing.



**WARNING!!** Always check the position of the power cord during the movements. Disconnect all electric power supplies before opening the boxes.

### 5.4.3. Start-up of 12V emergency electric pump (OPTIONAL for models "D")

Diesel power models are equipped with a 12V electrical pump for the operation of the booms (lifting, lowering, rotation) in the event of an emergency.

To start the emergency electrical pump by means of the **platform control panel**:

- Select the platform control panel with the locking key switch on the ground control unit.
- Unlock the emergency stop button (**D**) turning by a ¼ of turn clockwise.
- Set the drive power selector (**B**) to "Electric" position.
- Select the 12V power with selector (**E**) if 380V electric pump is present.
- Press and hold down the green button (**G**) as long as the desired operation has been carried out if only the 12V electric pump is present, press and hold down the green button (**H**) if also the 380V electric pump is present. In this condition the 12V emergency electrical pump is started.
- Press and hold down the dead-man pedal as long as the desired operation has been carried out.
- Operate the controls of the machine as indicated in previous paragraphs.



**WARNING!! To start the 12V emergency electrical pump it is necessary to follow the sequence of the above mentions operations.**

To start the emergency electrical pump by means of the **ground control panel**:

- Select the ground control panel with the key switch on the ground control unit keeping it active.
- Set the power selector (**B**) to "Electric" position.
- In this condition the 12V emergency electrical pump is started, and the machine controls can be operated as indicated in previous paragraphs.



**WARNING! The power by the 12V emergency electrical pump is only for platform lowering in case of faults in the main powers. Do not use it during normal work operations.**

## 5.5. Machine stop

### 5.5.1. Normal stop

In normal operating conditions:

- By releasing the controls the operation is stopped. Stop occurs within a time limit set in the factory, which guarantees smooth braking.
- By releasing the dead-man pedal located on the platform, the operation is immediately stopped. In the event of an immediate stop, braking is sudden.

### 5.5.2. Emergency stop button

Should it be necessary, the operator may immediately stop all machine functions on both platform and ground control panel.

On the platform control panel:

- press the emergency stop button on the control panel and the machine is turned off.
- By releasing the dead-man pedal, the operation is immediately stopped. In the event of an immediate stop, braking is sudden.

On the ground control panel:

- Press the stop button and the machine (all models) and the heat engine (models "D", "E/D"; "E/B") are stopped.
- Press the power emergency stop button (if available – "E" models), and the machine power (power circuit cut-out) is stopped.

**To resume the operations:**

On the platform control panel:

- turn the emergency stop button of 1/4 turn clockwise.

On the ground control panel:

- turn the emergency stop button of 1/4 turn clockwise.
- Pull the power circuit emergency stop button (if available) to the outside until it locks in position to power the machine again.

### 5.5.3. Diesel engine stop

In order to stop the Diesel engine:

On the platform control panel:

- Turn the starter key anticlockwise to position "0".
- Otherwise, press the emergency stop button.

On the ground control panel:

- Turn the starter key anticlockwise to position "0".
- Otherwise, press the emergency stop button.



**Do not stop the motor when the r.p.m. is high. Before stopping the motor wait until the r.p.m. is at the lowest.**



#### 5.5.4. Stopping the 380V three-phase or 230V single-phase electrical pump (optional)

To stop the electrical pump (optional):

On the platform control panel:

- Press the stop button.
- Otherwise, press the emergency stop button.

On the ground control panel:

- Press the emergency stop button.

## 5.6. Emergency manual controls



This function is to be used only in emergency situations, when no motive power is available.

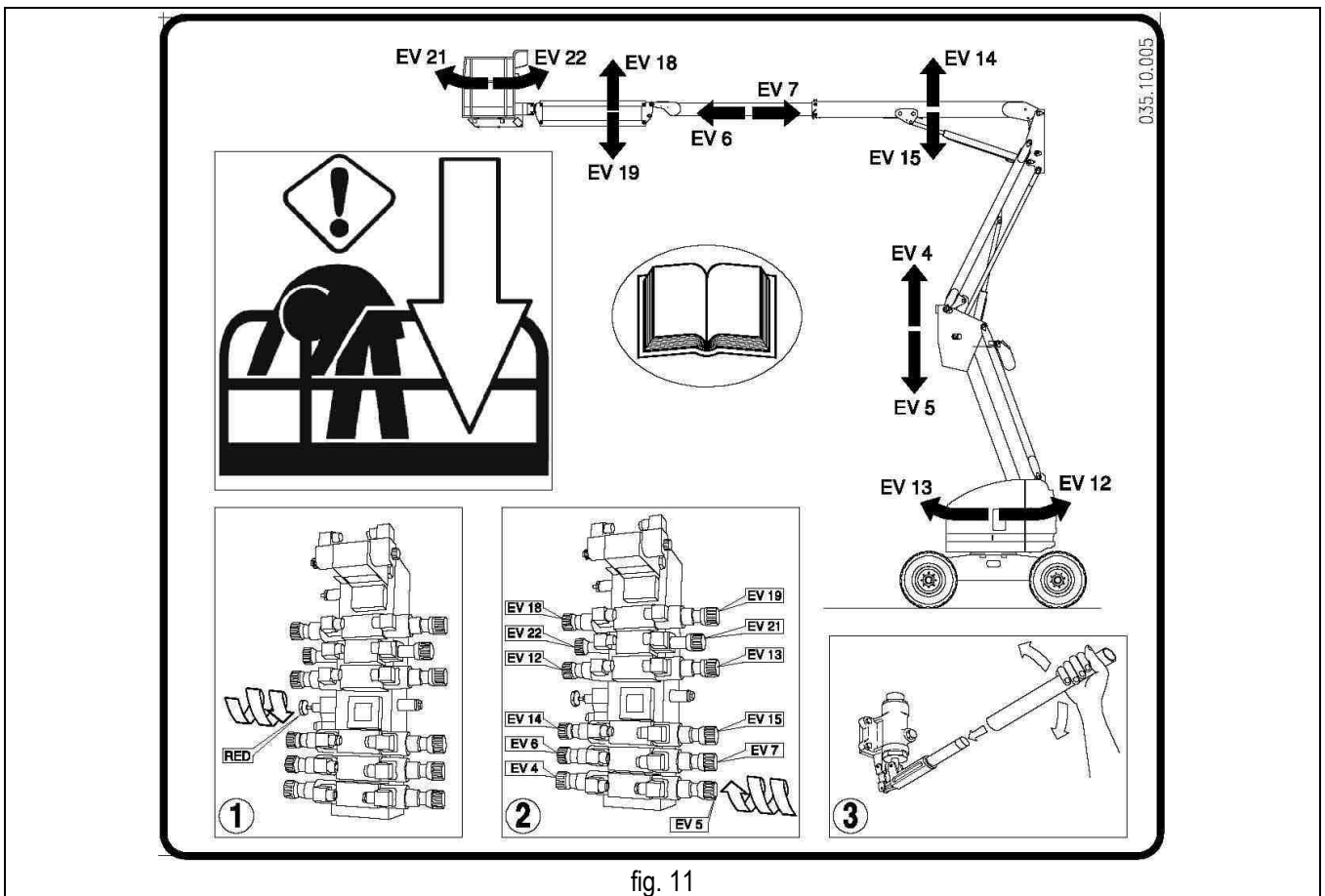

In case of fault in the electric or hydraulic system, carry out the following emergency procedures:

- 1) Screw the read tap completely (behind solenoid valve EV11).
- 2) Screw the knurled knob of the solenoid valve corresponding to the desired movement.
- 3) Insert the specially provided lever on the manual pump handle.
- 4) Activate the emergency pump.
- 5) Check the correct execution of this procedure.

Solenoid valves and relevant movements:

- EV4 = Pantograph up
- EV5 = Pantograph down
- EV6 = Telescopic boom out
- EV7 = Telescopic boom in
- EV12 = Turret right rotation
- EV13 = Turret left rotation
- EV14 = Boom up
- EV15 = Boom down
- EV18 = Lifting Jib
- EV19 = Lowering Jib
- EV21 = Platform right rotation
- EV22 = Platform left rotation



**WARNING:** The emergency control can be stopped at any moment by releasing the knob or by stopping the pump.



Once this emergency manoeuvre has been carried out, the knurled knobs and the tap must be set to their initial position again in order to resume the operations (in normal position the knobs are completely unscrewed).

### 5.7. Socket for electric tool connection (optional)

The work platform can be equipped with a socket (230V Ac) enabling the operator to connect the electric tools necessary to carry out his operations.

To activate the electric line (see pictures above) introduce a cable into the plug connected to the 230V AC 50 Hz mains, with all protections according to the current standards in force. If there is the circuit breaker switch (optional), to activate the electric line set the switch to ON position. It is advisable to check the earth-leakage circuit breaker by means of the specially provided TEST button.

The plugs and sockets equipped on standard machines comply with EEC standards and can therefore be used in EU member countries. On request the machine can be equipped with plugs and sockets in compliance with local standards or with particular needs.



Fig. 12



Connect to the power mains having the following features:

- Power voltage 230V  $\pm$  10%
- Frequency 50 $\pm$ 60 Hz
- Activated grounding line.
- Working protection devices according to current standards in force.
- Do not use extension leads exceeding 5 metres to connect to the mains.
- Use a cable of suitable section (min 3x2.5 mm<sup>2</sup>).
- Do not use rolled-up cables.

### 5.8. Fuel level and re-fuelling (models “ED”, “D”)

Before using the thermic drive power (Diesel engine) check the fuel level in the tank.

This operation is to be carried out by visually checking the fuel level after unscrewing the filler cap.

- Visually check the fuel level before starting to work.
- Keep the fuel tank and the motor clean.

## 5.9. End of work

After stopping the machine according to the instructions given in the previous paragraphs:

- Always set the machine to rest position (platform completely lowered).
- Press the emergency Stop button on the ground control panel.
- Remove the keys from the control panel to prevent unauthorized people from using the machine.
- Recharge the battery according to the instructions given in section "Maintenance" (models "E" and "ED" only).
- To fill the tank (if it applies).

## 6. HANDLING AND CARRYING

### 6.1. Handling

Before using the machine, make sure that the mechanical lock device of the turret is disabled (see figure aside).

To handle the machine in normal operating conditions follow the instructions given in chapter "USE INSTRUCTIONS" under paragraph "Drive and steering".

When the platform is completely lowered (booms down, telescopic boom completely in and jib at a height between  $+10^{\circ}$  and  $-70^{\circ}$  with respect to horizontal axis) the machine can be handled (i.e. drive can be performed) at different speeds to be freely selected by the user.

When the platform is lifted and exceeds a given height, the enabled machines (see chapter "Technical Features") can be driven at a reduced speed (automatically) up to the height specified in chapter "Technical Features".

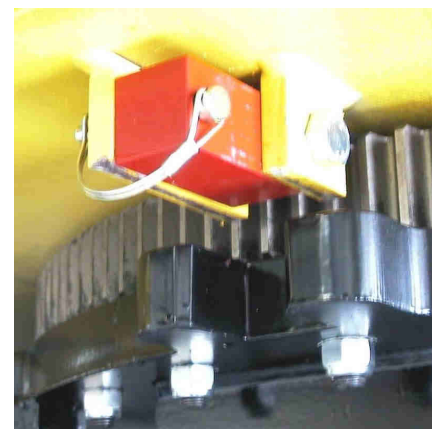
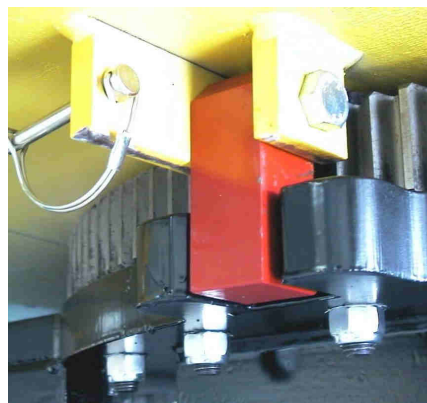

Fig. 13



#### **WARNING!**

Drive with lifted platform may be subject to different restrictions according to the country where the machine is used. Find out about the legislative limits concerning this operation from the bodies of Health and Safety at work.

It is absolutely forbidden to drive the machine when platform is lifted unless the ground is horizontal, flat and steady.

Before carrying out any displacement operation, verify that no people are in proximity of the machine and in any case proceed with the utmost caution.

Before handling the machine check that the connection plugs are disconnected from the power supply source.

Check that there are no holes or steps on the floor and bear in mind machine overall dimensions.

Do not use the machine to tow other vehicles.

Before steering and driving the machine, check the actual position of the rotating turret (see the relevant stickers on the chassis) so as to achieve the correct movement direction.

While the machine is being displaced with lifted platform, no horizontal loads can be loaded onto the platform (operators on board are not allowed to pull wires or ropes, etc.).

## 6.2. Carrying

In order to carry the machine to the various working sites, follow the instructions given below. Considering the large dimensions of some models, before carrying, it is recommended to inquire about the overall dimension limits for road transport in force in your country.



**Before carrying the machine, turn it off and remove the keys from the control panels. No people are allowed in proximity to or on the machine to avoid any risks deriving from sudden movements. For safety reasons never lift or tow the machine by means of its booms or platform. Loading operations are to be carried out on a flat surface with a suitable capacity, after setting the platform to rest position.**

To carry the machine the operator shall load it onto a vehicle either:

- **By means of loading ramps and translation controls** located on the platform to load it directly onto the machine (if ramp slope is within the gradeability described in paragraph “TECHNICAL FEATURES” and ramp capacity is adequate to weight) according to the instructions given in paragraph “USE INSTRUCTION” under paragraph “Drive and steering” for correct operation of drive controls. During the loading operation following this system, it is best to raise the Jib (not over +10° with respect to the horizontal to prevent engaging the safety speed) to prevent the platform knocking against the ground. Pay attention not to load other booms during this operation to prevent the emergency microswitches from being activated, which in case of inclined machine disable all the manoeuvres except the lowering ones. If the slope exceeds the gradeability, the machine is to be towed by means of a windlass only if the operator on the platform simultaneously activates the drive control to release the parking brakes. The gradient can be determined using an electronic level or empirically as described below: position a wood board of known length on the gradient to be measured. Position a spirit level on the wood board and lift the downstream extremity of the latter until it is level. Now measure the distance between the board and the ground (**A**), divide this by the length of the board (**B**) and multiply by 100. The following image sums up the method.

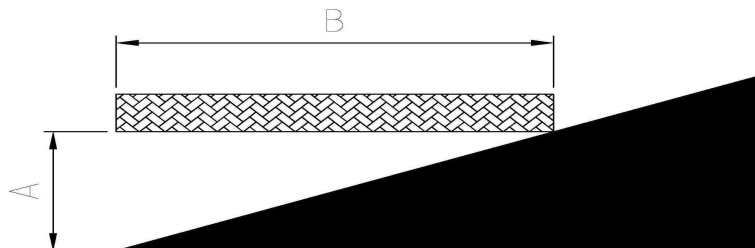

- **By means of hooks and steel ropes** (with safety factor = 5, see machine weight in Technical features) connected to the provided holes as indicated in the picture aside.



Fig. 14

- **Through a lift truck** of a suitable capacity (see machine weight in table “Technical features” at the beginning of this manual) equipped with forks having at least the same length as the machine width. Insert the forks as indicated by the stickers on the machine.

- Should these stickers be not available, DO NOT lift the machine by means of a lift truck. Lifting the machine by means of a lift truck is a dangerous operation, which must be carried out by qualified operators only.



**After placing the machine onto the carrying vehicle, fasten it by means of the same holes used for lifting. To avoid breaking the platform overload controller, thus causing the machine to stop, DO NOT fix the machine to the vehicle base by tying the platform (any model) or the last lifting boom.**



**Lock the turret by means of the mechanical safety lock device as specified in the previous chapters.**



**Before carrying the machine check the stability grade. The platform must be fully lowered and the platform extension must be in retracted position to ensure adequate stability during the entire operation.**

### 6.3. Emergency towing of the machine

In the event of a fault, carry out the following operations to tow the machine:

- Hook the machine to the provided holes.
- Loosen the three fixing screws of the central covers of all drive reduction gears (the reduction gears are 2 if the machine has two driving wheels or 4 if it has four driving wheels).
- Turn the covers clockwise so that the oversize holes match with the screw heads.
- Remove the covers and insert them again upside down exercising some pressure to withstand the resisting force of a spring inside the reduction gears.
- Turn the covers clockwise so that the three screws keep them pressed and tighten the screws.
- Tow at a very slow speed (remember that when the machine is being towed, brakes are out of order).



**WARNING! THIS OPERATION MAY CAUSE OIL LEAKAGE FROM THE DRIVE REDUCTION GEARS.**

To resume the normal operation, set back the machine to initial conditions and, if necessary, top up the oil level inside the drive reduction gears.



**Tow at a very slow speed (remember that when the machine is being towed, brakes are out of order).**

**Tow only on a flat ground.**

**Do not park the machine without brakes on. Should the brakes be completely out of order put wedges under the wheels to prevent the machine from moving accidentally.**



## 7. MAINTENANCE



- Always carry out maintenance operations when the machine is still and after having removed the key from the control panel with the platform in rest position.
- The maintenance operations described below refer to a machine with ordinary working use. In case of difficult conditions of use (extreme temperatures, corrosive environments, etc.) or following long machine inactivity, it will be necessary to contact the AIRO assistance service to change the intervention schedule.
- Repairs and maintenance operations are to be carried out by trained and authorised personnel only. All maintenance operations should be carried out in compliance with the current work safety regulations (work places, personal protection equipment, etc...).
- Carry out only the maintenance and adjustment operations described in this user manual. In emergency situations (e.g. breakdown, wheels replacement) contact Our Technical Support.
- During interventions, check that the machine is completely locked. Before carrying out maintenance operations inside the lifting structure, check that this is off-line in order to avoid accidental lowering of the booms.
- Remove the battery cables and provide batteries with a suitable protection during welding operations.
- Carry out maintenance operations on the heat motor only when it is not running and sufficiently cool (except for those operations, such as oil change, which must be performed when the motor is hot). Risk of burns in contact with hot parts.
- Do not use petrol or other flammable materials to clean the heat motor.
- For maintenance operations on the heat motor, read the manufacturer's manual of the motor supplied on machine purchase.
- In case of replacement, use original spare parts only or spare parts approved by the manufacturer.
- Disconnect the 230V AC and/or 380V AC sockets, if any.
- The lubricants, hydraulic oils, electrolytes and all detergent products should be handled with care and disposed of in safety according to the current regulations. A prolonged contact with the skin may cause irritations and dermatosis; wash with water and soap and rinse thoroughly. Contact with eyes, especially with electrolytes, is also dangerous; rinse with water thoroughly and call the doctor.



**WARNING!**  
**NEVER MODIFY OR TAMPER WITH MACHINE PARTS TO IMPROVE THE MACHINE PERFORMANCE AS THIS MAY AFFECT ITS SAFE OPERATION.**

### 7.1. Machine cleaning

To clean the machine use non-pressurized water jets after properly protecting the following parts:

- The control panel (both platform and ground).
- the electric ground control unit and all electric boxes in general.
- The electric motors.



**Do not use pressurized water jets (high-pressure cleaners) to clean the machine.**

After washing the machine, always:

- Dry the machine.
- Check integrity of plates and stickers.
- Lubricate the articulated joints equipped with greaser.

## 7.2. General maintenance

Below are listed the main maintenance jobs to be done and the relevant schedule (the machine features an hour meter).

Operation	Frequency
Screw tightening (see paragraph "Various adjustments")	After the first 10 working hours
Oil level check in hydraulic tank	After the first 10 working hours
Check of the battery state (charge and liquid level)	Every day
Check of deformation of tubes and cables	Every week
Check of stickers and code plates	Every month
Articulated joints and sliding blocks greasing	Every month
Check of heat motor fixing on elastic supports	Every month
Emergency devices efficiency check	Every year
Electric connections check	Every year
Hydraulic connections check	Every year
Periodic operation check and structure visual check	Every year
Screw tightening (see paragraph "Various adjustments")	Every year
Check of drive and rotation reduction gear oil change	Every year
Turret rotation clearance adjustment	Every year
Operation check of movement circuit pressure relief valve	Every year
Operation check and adjustment of the braking system	Every year
Air purging from oscillating axe cylinders	Every year
Operation check of the turret inclinometer	Every year
Operation of inclinometer in platform (where present - optional) check	Every year
Operation check of platform overload controller	Every year
Visual check of wear condition of chains of boom extraction (A23 J only)	Every year
Check/adjustment of tension of chains of boom extraction (A23 J only)	Every year
Operation check of M1 microswitches	Every year
Operation check of Microswitch M9 (if available)	Every year
Operation check of Microswitch and proximity sensor M10	Every year
Operation check of proximity sensors M11 and M12	Every year
Operation check of proximity sensor M13	Every year
Operation check of microswitch M14 (A23 J only)	Every year
Operation check of microswitch M15 (A23 J only)	Every year
Operation check of dead-man pedal safety system	Every year
Telescopic boom sliding blocks clearance adjustment	Every year
Hydraulic filter replacement	Every two years
Drive and rotation reduction gear oil change	Every two years
Total oil change in hydraulic tank	Every two years



**DIESEL (D) AND ELECTRIC-DIESEL (ED) MODELS** As it is possible to install different types of Diesel engines, refer to the instructions manual of the engine manufacturer for all maintenance operations.



**TO SEND THE MACHINE TO THE MANUFACTURER WITHIN 10 YEARS OF WORK FOR A COMPLETE CHECK**



**BIODEGRADABLE OIL KIT  
PANOLIN BIOMOT 10W40**

### 7.2.1. Various adjustments

Check the conditions of the following components and, if necessary, tighten after the first 10 working hours and, afterwards, at least once a year:

- 1) Wheel screws
- 2) Drive motor fixing screws
- 3) Steering cylinder fixing screws
- 4) Fixing screws of steering hub pins
- 5) cage fixing screws
- 6) Hydraulic fittings
- 7) screws and safety dowels of boom pins
- 8) Rotation reduction gear fixing screws
- 9) Elastic supports of heat engine

For torque wrench setting refer to the table below.

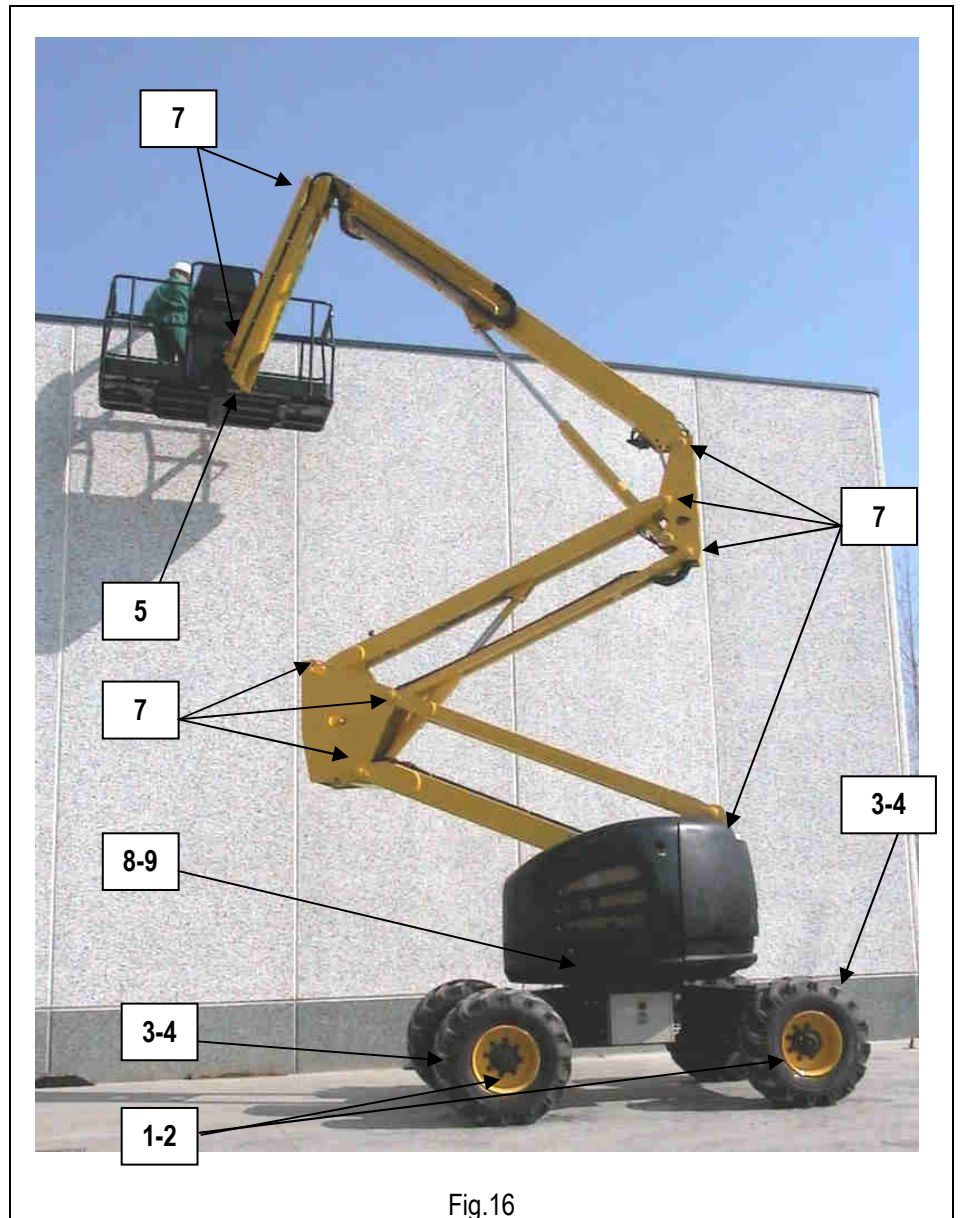

Fig.16

TORQUE WRENCH SETTING (S.I. thread, normal pitch)						
Class	8.8 (8G)		10.9 (10K)		12.9 (12K)	
Diameter	kgm	Nm	kgm	Nm	kgm	Nm
M4	0.28	2.8	0.39	3.9	0.49	4.9
M5	0.55	5.5	0.78	7.8	0.93	9.3
M6	0.96	9.6	1.30	13.0	1.60	16.0
M8	2.30	23.0	3.30	33.0	3.90	39.0
M10	4.60	46.0	6.50	65.0	7.80	78.0
M12	8.0	80.0	11.0	110	14.0	140
M14	13.0	130	18.0	180	22.0	220
M16	19.0	190	27.0	270	33.0	330
M18	27.0	270	38.0	380	45.0	450
M20	38.0	380	53.0	530	64.0	640
M22	51.0	510	72.0	720	86.0	860
M24	65.0	650	92.0	920	110	1100

## 7.2.2. Greasing

Grease all articulated joints equipped with greaser (or predisposition for greaser) at least every month.

At least once a month, using a spatula or a brush, lubricate the telescopic extension.

Moreover, always remember to grease the articulated joints:

- After washing the machine.
- Before using the machine again after a long time-interval.
- After using the machine in adverse environmental conditions (high humidity levels; presence of dust; coastal areas, etc).

Grease all points indicated in the picture aside (and all articulated joints equipped with greaser) with grease type

**ESSO BEACON-EP2** or equivalent.

**(OPTIONAL BIODEGRADABLE OIL KIT)  
PANOLIN BIOGREASE 2**

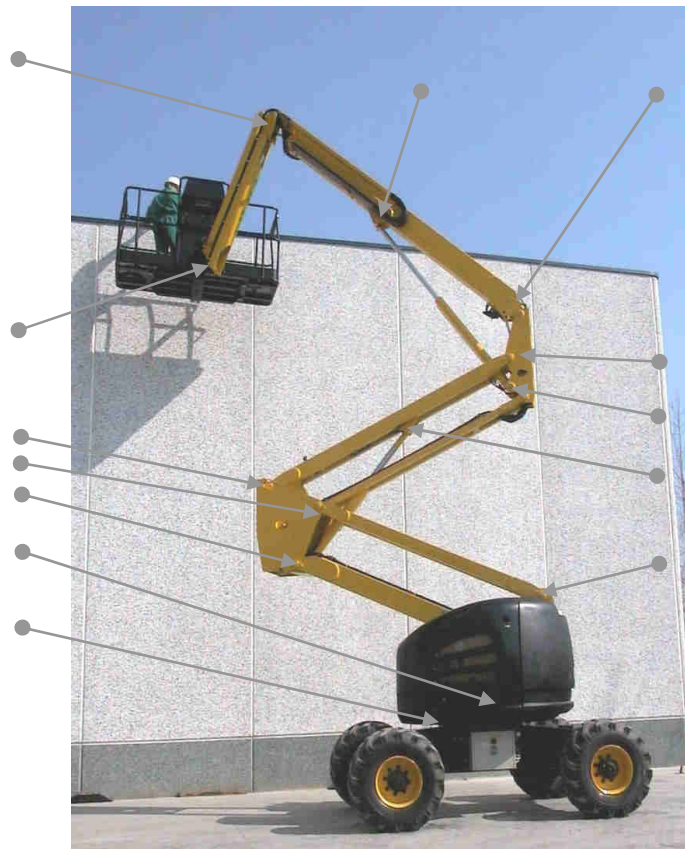

Fig. 17

### 7.2.3. Hydraulic circuit oil level check and change

Check after the first 10 working hours and, afterwards, once a month the level by means of the provided indicator (detail **A** in the picture aside) and make sure that the level always lies between the max. and min. values. If necessary top up until max. level is reached. The oil check should be carried out when platform is completely lowered and telescopic boom in.

Completely change the hydraulic oil at least every two years.

To empty the tank:

- Lower the platform completely and retract the telescopic boom extension.
- Stop the machine by pressing the emergency stop button of the ground control panel.
- Place a container under cap (**B**), under the tank, and unscrew it.

Use only the types of oil and quantity indicated in the table below.

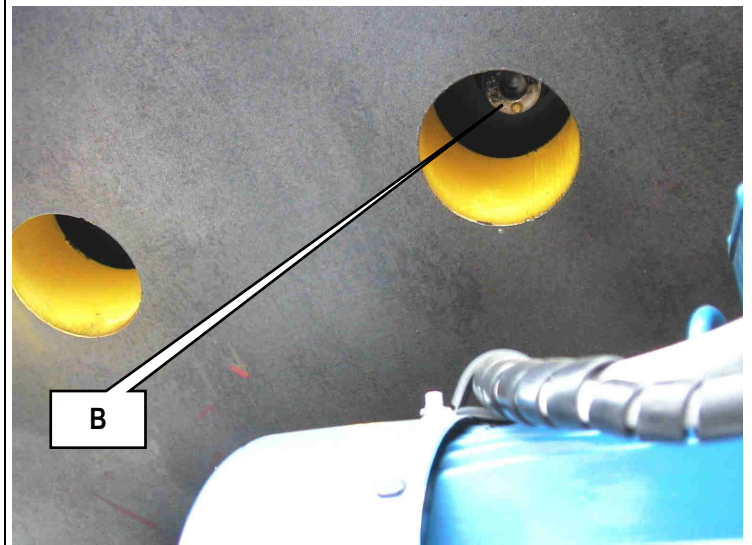
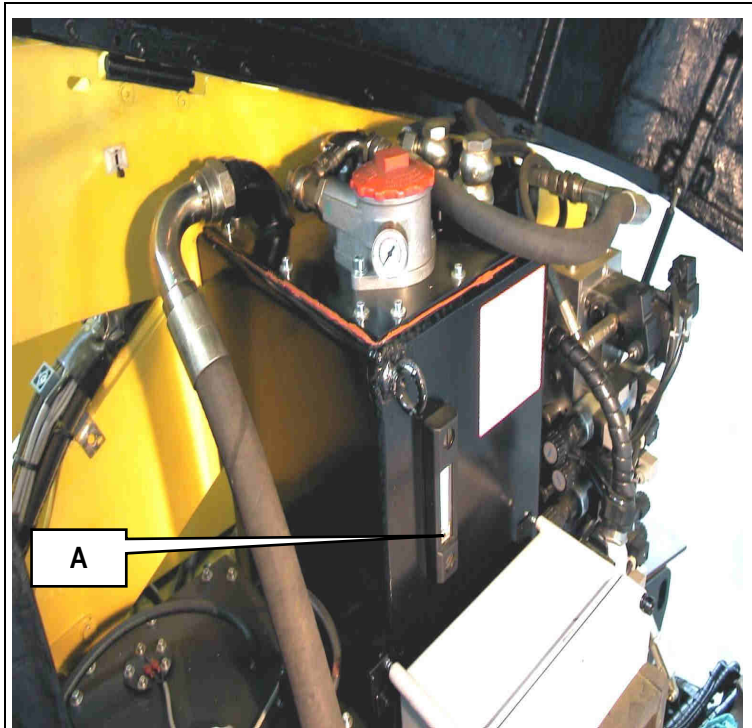

fig. 18

HYDRAULIC SYSTEM OIL			
BRAND	TYPE		REQUIRED QUANTITY
	-20°C	+79°C	
SYNTHETIC OILS			120 litres
ESSO	Invarol EP46	Invarol EP22	
AGIP	Arnica 46	Arnica 22	
ELF	Hydrelf DS46	Hydrelf DS22	
SHELL	Tellus SX46	Tellus SX22	
BP	Energol SHF46	Energol SHF22	
TEXACO	Rando NDZ46	Rando NDZ22	
Q8	LI HVI 46	LI HVI 22	
PETRONAS	HIDROBAK 46 HV	HIDROBAK 22 HV	
BIODEGRADABLE OILS - OPTIONAL			
PANOLIN	HLP SINTH E46	HLP SINTH E22	



**Do not dispose of used oil in the environment. Comply with the current local standards.**

The lubricants, hydraulic oils, electrolytes and all detergent products should be handled with care and disposed of in safety according to the current regulations. A prolonged contact with the skin may cause irritations and dermatosis; wash with water and soap and rinse thoroughly. Contact with eyes, especially with electrolytes, is also dangerous; rinse with water thoroughly and call the doctor.

### 7.2.3.1 Biodegradable hydraulic oil (Optional)

At the request of the customer, the machines can be supplied with biodegradable hydraulic oil compatible with the environment. Biodegradable hydraulic oil is completely synthetic, without zinc, non-polluting and highly efficient with saturated ester base, combined with special additives. The machines with biodegradable oil use the same component parts as standard machines, but the use of such type of oil is best taken into account from machine construction. In case of wanting to change from mineral-oil based hydraulic oil to “bio” oil, the following procedure must be followed.

### 7.2.3.2 Emptying

Empty the hot hydraulic oil for entire system operation (oil tank, cylinders, large-volume pipes).

### 7.2.3.3 Filters

Change the filtering inserts. Use standard filters as indicated by the manufacturer.

### 7.2.3.4 Washing

After completely emptying the machine, fill with a nominal quantity of “bio” hydraulic oil. Start the machine and perform all work movements at low revs for at least 30 minutes. Empty the liquid inside the systems as indicated at 7.2.3.1.1.

**Warning:** During the entire washing procedure, avoid air entering the system.

### 7.2.3.5 Filling

After washing, fill the hydraulic circuit, bleed and check the level. Bear in mind that contact of fluid with the hydraulic pipes can cause swelling. Also remember that contact of fluid with the skin can cause reddening or irritation. Also use suitable PPE during these operations (e.g., protective eyewear and gloves).

### 7.2.3.6 Commissioning / check

“Bio” oil behaves regularly, but it must be checked by taking a sample at set intervals according to the indications provided below:

CHECK FREQUENCY	NORMAL DUTY	HEAVY DUTY
1 <sup>st</sup> CHECK AFTER	50 OPERATING HOURS	50 OPERATING HOURS
2 <sup>nd</sup> CHECK AFTER	500 OPERATING HOURS	250 OPERATING HOURS
3 <sup>rd</sup> CHECK AFTER	1000 OPERATING HOURS	500 OPERATING HOURS
FOLLOWING CHECKS	1000 HOURS OR 1 OPERATION YEAR	500 HOURS OR 1 OPERATION YEAR



The fluid state is therefore constantly monitored, thus allowing its use until its features decay. Normally, in the absence of contaminating agents, the oil is never completely changed, but only occasionally topped-up.

The oil samples (at least 500ml) must be taken with the system at operating temperature.  
It is recommended to use new and clean containers.

The samples must be sent to the "bio" oil supplier.  
For more dispatch details, contact Your nearest distributor.

**Copies of the analysis report must be kept in the check register. This is mandatory.**

#### **7.2.3.7 Mix**

Mixtures with other biodegradable oils are not allowed.  
The remaining amount of mineral oil must not exceed 5% of total filling quantity as long as the mineral oil is suitable for the same use.

#### **7.2.3.8 Micro-filtration**

When making the conversion on second-hand machines, always take into account the high dirt dissolution power of biodegradable oil.

After conversion, the dissolution of fault-causing deposits in the hydraulic system could occur. In extreme cases, washing the seal housings can cause greater leaks.

To prevent faults as well as avoid any negative effect on oil quality, after the conversion, it is best to filter the hydraulic system using a micro-filtration system.

#### **7.2.3.9 Disposal**

The biodegradable oil, inasmuch as saturated ester, is suitable for both thermal and material re-use.

It therefore provides the same disposal / re-use options as mineral based old oil.

Such oil can be incinerated whenever local laws allow.

Recycling the oil is preferable to disposal on dumps or incineration.

#### **7.2.3.10 Topping up**

The oil must **ONLY EVER** be topped up with the same product.

**Note:** Max water contamination is 0.1%.



**During oil change or topping up, do not discard the hydraulic oil in the environment.**

## 7.2.4. Hydraulic filter replacement

### 7.2.4.1. Suction filters

#### 7.2.4.1.1. Main gear pump filter

All models are equipped with a suction filter installed inside the tank at the base of the suction tube, which has to be replaced at least every two years.

To replace the suction filters installed inside the tank (see figure):

- Stop the machine by pressing the emergency stop button of the ground control unit.
- Unscrew the tank cover with the metal suction tubes.
- Extract the cover from the tank.
- Unscrew filter from the suction tube and replace.
- To restore the initial condition, carry out the above-mentioned operation in reverse order.

During these operations a quantity of oil may leak out. In this case remove the oil by means of cloths and by pouring it into a specific container.





### 7.2.4.1.2. Filter of electrical pumps, 380V (OPTIONAL) and 12V (emergency on Diesel models)

The models equipped with a 380V electrical pump (OPTIONAL) and/or a 12V emergency pump have an extra suction filter inside the suction tube, which has to be replaced at least every two years.

To replace the suction filters installed inside the tank (see figure):

- Stop the machine by pressing the emergency stop button of the ground control unit.
- Unscrew the tank cover with the metal suction tubes.
- Extract the cover from the tank.
- Unscrew filter from the suction tube and replace.
- To restore the initial condition, carry out the above-mentioned operation in reverse order.

During these operations a quantity of oil may leak out. In this case remove the oil by means of cloths and by pouring it into a specific container.

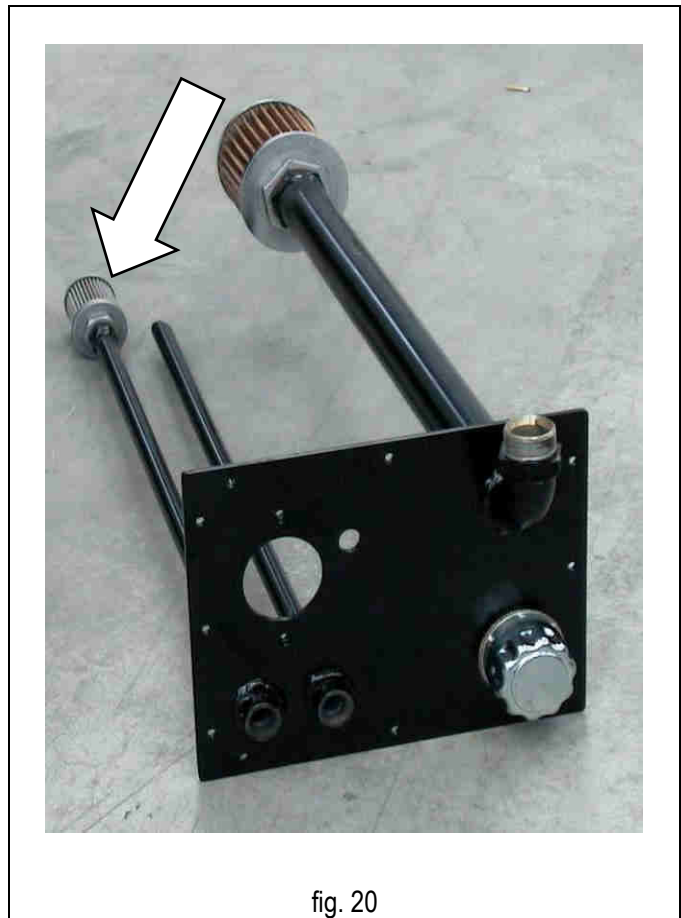

#### 7.2.4.2. Return filter

The return filter directly flanged on the tank is equipped with a visual clogging indicator. During normal operation, the visual indicator is in the green zone. When the indicator is in the red zone, the filtering cartridge is to be replaced. However the filtering cartridge should be replaced at least every two years. To replace the filtering cartridge:

- Stop the machine by pressing the emergency stop button on the ground control unit.
- Remove the filter cover.
- Remove the cartridge.
- Fit the new cartridge paying attention to the correct position of the retaining spring and place the cover again.

During these operations a quantity of oil may leak out. In this case remove the oil by means of cloths and by pouring it into a specific container.

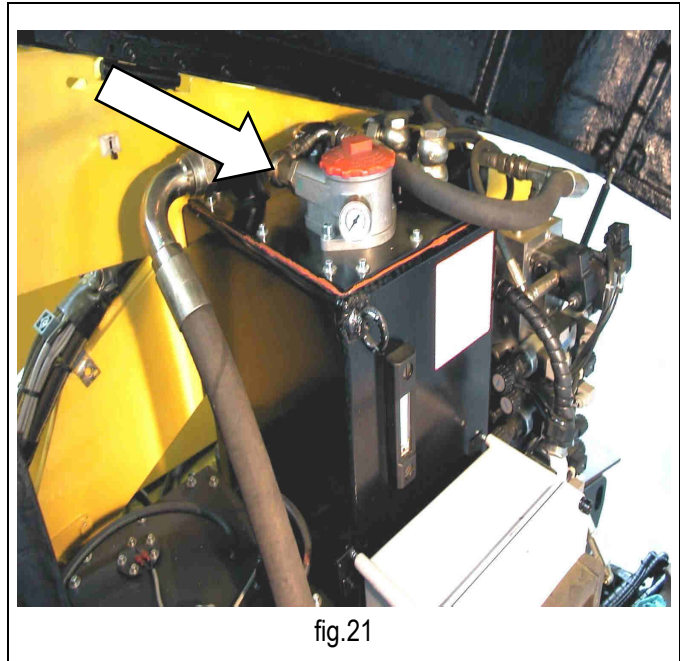

fig.21



**IT IS FORBIDDEN to start the machine when the filter cover is missing or not properly tightened.**

**Replace the filters using only original accessories available at our Technical Support.**

**Do not re-use used oil and do not leave it in the environment, but dispose of in compliance with local standards in force.**

**Once the filters have been replaced, check the hydraulic oil level in the tank.**

### 7.2.5. Turret rotation reduction gear oil level check and change

The oil level should be checked at least once a year. Check the level by means of cap (A). Oil check must be carried out when the oil is hot. The level is correct when the reduction gear body is full of oil up to the cap limit. Should a lubricant volume higher than 10% be topped up, check that there is no oil leakage in the system. Do not mix different types of oil, of the same or of different brands. Do not mix mineral oils and synthetic oils.

The oil must be changed the first time after 50-100 working hours, and afterwards after every two years. Depending on the actual operating conditions, these intervals may be varied for each single case. While changing the oil it is advisable to wash the internal part of the cover with a fluid recommended by the lubricant producer. To avoid sludge deposits, the oil must be changed when the reduction gear is hot.

To change the oil, unscrew caps (A) and (C) and place a container of at least 3-litre capacity under cap (C). Empty the reduction gear body completely, clean it as described above and then fill it up to the limit level of the cap (C) (for max. capacity see table at next page through cap (A)).



fig. 22

LUBRICATING OIL FOR REDUCTION GEAR TURRET ROTATION		
BRAND	TYPE	REQUIRED QUANTITY
SYNTHETIC OILS		
ESSO	Compressor Oil LG 150	2,5 litres
AGIP	Blasia S 220	
CASTROL	Alpha SN 6	
IP	Telesia Oil 150	
BIODEGRADABLE OILS - OPTIONAL		
PANOLIN	Biogear 80W90	

#### 7.2.5.1 Checks in the use of synthetic biodegradable oil in turret rotation reduction gears

Quarterly or every 500 hours check the oil level. In case of need top up. If you notice that more than 10% of oil lacks in the reduction gear, check if there are any leaks.

Change the oil in the rotation reduction gear after the first 100 hours of operation and then every 6000 hours or every 3 years depending on the actual operating conditions, these intervals may change.

When changing the oil it is recommended that you run a wash cycle inside the cover.

Change the oil when the reduction gear is hot.

Mixtures of different oils (either biodegradable or mineral) even of the same brand are not allowed.

## 7.2.6. Drive reduction gear oil level check and change

The oil level should be checked at least once a year. Position the machine until the two caps (A and B) reach the position indicated in the picture aside. Check the level by means of cap (A). Oil check must be carried out when the oil is hot. The level is correct when the reduction gear body is full of oil up to the cap limit (A). Should a lubricant volume higher than 10% be topped up, check that there is no oil leakage in the system. Do not mix different types of oil, of the same or of different brands. Do not mix mineral oils and synthetic oils.

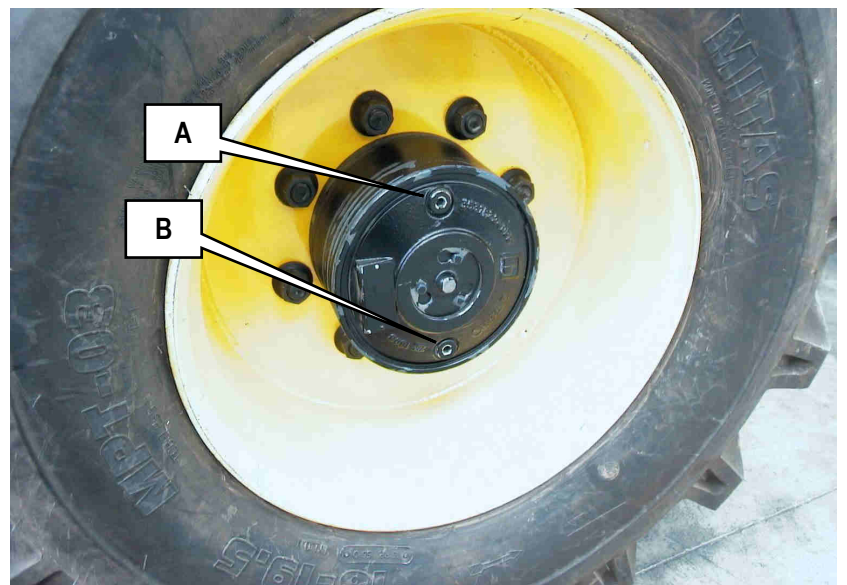

fig. 23

The oil must be changed the first time after 50-100 working hours, and afterwards after every 2500 working hours or at least every two years. Depending on the actual operating conditions, these intervals may be varied for each single case. While changing the oil it is advisable to wash the internal part of the cover with a fluid recommended by the lubricant producer. To avoid sludge deposits, the oil must be changed when the reduction gear is hot. To change the oil unscrew cap B, and place a container of a 2-litre capacity under it. Empty the reduction gear body completely, clean it as described above and then fill it up to the limit level of cap A through the same hole (for max. capacity see following table).

<b>LUBRICATING OIL FOR DRIVE REDUCTION GEARS</b>		
<b>BRAND</b>	<b>TYPE</b>	<b>REQUIRED QUANTITY</b>
<b>SYNTHETIC OILS</b>		
ESSO	Compressor Oil LG 150	1 litre for each reduction gear
AGIP	Blasia S 220	
CASTROL	Alpha SN 6	
IP	Telesia Oil 150	
<b>BIODEGRADABLE OILS - OPTIONAL</b>		
PANOLIN	PANOLIN	

### 7.2.6.1 Checks in the use of synthetic biodegradable oil in drive reduction gears

Quarterly or every 500 hours check the oil level. In case of need top up. If you notice that more than 10% of oil lacks in the reduction gear, check if there are any leaks.

Change the oil in the rotation reduction gear after the first 100 hours of operation and then every 6000 hours or every 3 years.

Depending on the actual operating conditions, these intervals may change.

When changing the oil it is recommended that you run a wash cycle inside the cover.

Change the oil when the reduction gear is hot.

Mixtures of different oils (either biodegradable or mineral) even of the same brand are not allowed.

### 7.2.7. Air purging from oscillating axle locking cylinders

Once drive has been stopped and with raised platform, the axle locking cylinders are locked in position thus increasing the machine stability.

Check that no air is present inside the oscillating axial cylinders every year.

To check for perfect operation, proceed as follows:

- Remove the protection cylinder crankcases (A) of the oscillating axle.
- Unscrew the cap (B) of one of the two cylinders of the oscillating axle.
- Carry out the drive operation by bringing the two oscillating axle cylinders to end stop several times, until there is only oil leaking out of the cap of the locking valve.
- Once purging has been completed, screw cap (B) and check the oil level in the tank.

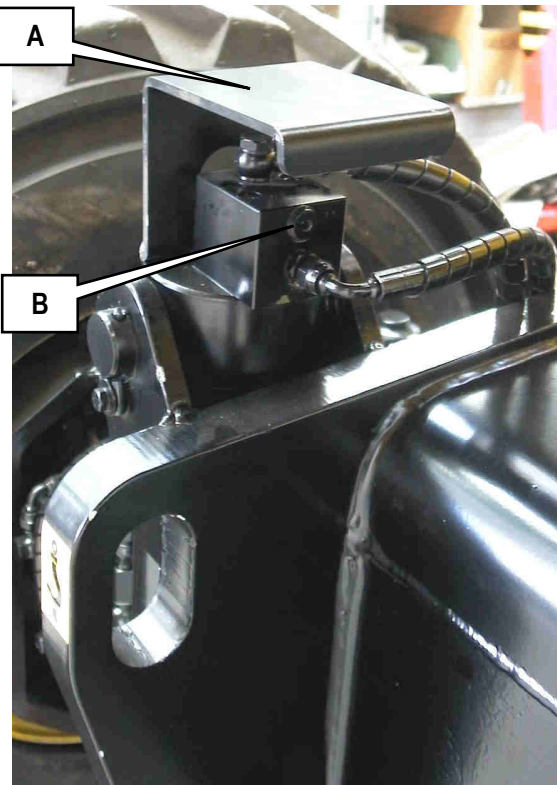

Fig.24

#### WARNING!

**THIS OPERATION OUGHT TO BE CARRIED OUT SIMULTANEOUSLY BY TWO OPERATORS: ONE IS TO DRIVE THE MACHINE, THE OTHER IS TO CHECK THE OPERATION AND COLLECT THE LEAKING OIL.**



**THIS OPERATION SHOULD BE CARRIED OUT IN ROOMS THAT ALLOW THE OIL LEAKING FROM THE CYLINDERS TO BE RECOVERED.**

**AS THIS OPERATION IS VERY IMPORTANT IT IS TO BE CARRIED OUT BY SKILLED TECHNICIANS ONLY.**

### 7.2.8. Turret rotation clearance adjustment

Check the coupling between the rotation pinion and the turntable should be carried out every year.

In normal operating conditions, the coupling clearance must be minimum. Otherwise, adjust according to the following instructions:

- Unscrew the four cylinder head screws (A) which fix the reduction gear support to the turret.
- unscrew both adjusting screws (C) to minimize clearance.
- Tighten the two lock-nuts (B).
- Screw the four screws (A).

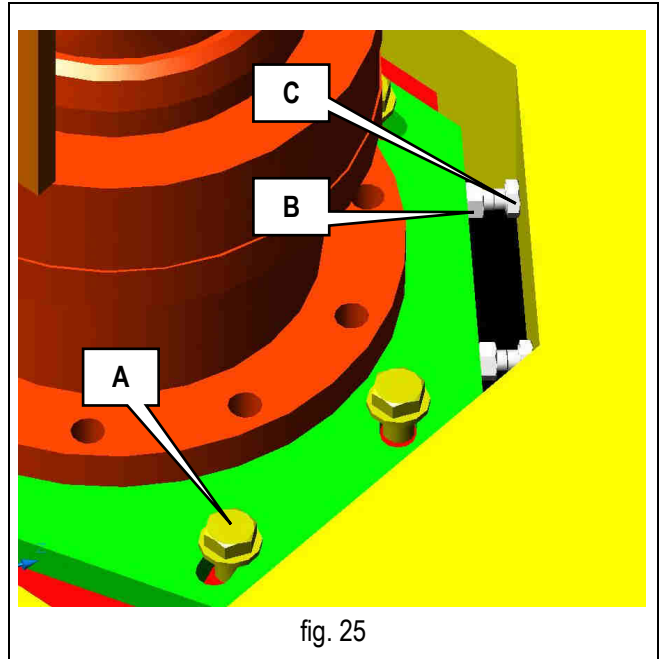

**WARNING!**  
AS THIS OPERATION IS VERY IMPORTANT IT IS TO BE CARRIED OUT BY SKILLED TECHNICIANS ONLY.

### 7.2.9. Telescopic boom sliding blocks clearance adjustment

Check the wear of the telescopic boom sliding blocks every year.

The correct clearance between the blocks of the boom is 0,5-1 mm; in case of higher clearance tighten the sliding blocks as follows:

- Unscrew dowel A.
- Screw the sliding block B with a suitable screwdriver until the above mentioned clearance is reached.
- Screw dowel A again.

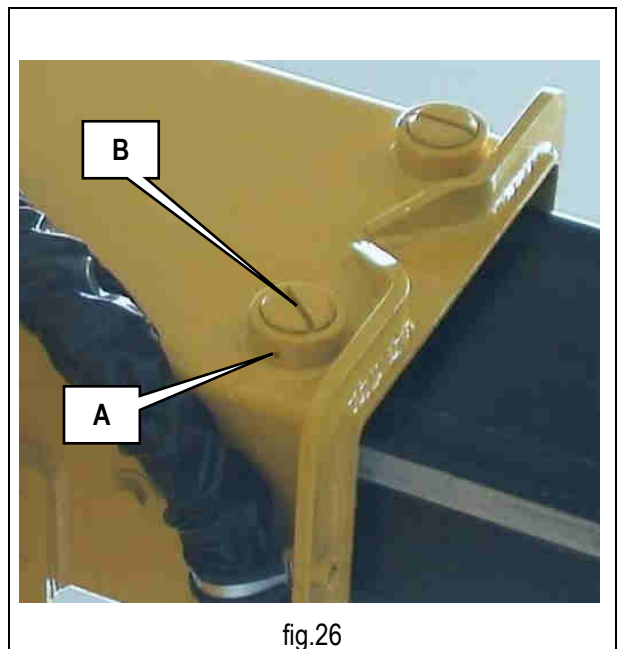

**WARNING!**  
AS THIS OPERATION IS VERY IMPORTANT IT IS TO BE CARRIED OUT BY SKILLED TECHNICIANS ONLY.



### 7.2.10. Visual check of wear condition of chains of boom extraction (A23 J only)

Every year check the wear condition of chains of extraction of the telescopic boom.

The type of chain used is Fleyer **BL466**, the pitch **12.7 mm (\*)**.

The check is to be carried out by measuring 10 pitches.

The max. allowed extension in the most worn-out section is to be 3%.

Then if the measuring of 10 pitches is higher than **130.8 mm** ( $127 + 3\%$ ) the chain is to be considered worn-out and needs replacing.

To check the extraction chains, extract the telescopic boom for about 1 metre, and carry out the above mentioned operations according to the position in the picture **A**.

To check the re-entry chains perform the operations described above, positioning as indicated in the figure **B**.

(\*) Note: the type of chain used may change depending on the manufacturing changes not necessarily indicated in the manual. If the chain used was not of the type prescribed, ask the after-sales service for the correct type.

The rule indicated for determining the wear condition is always valid.

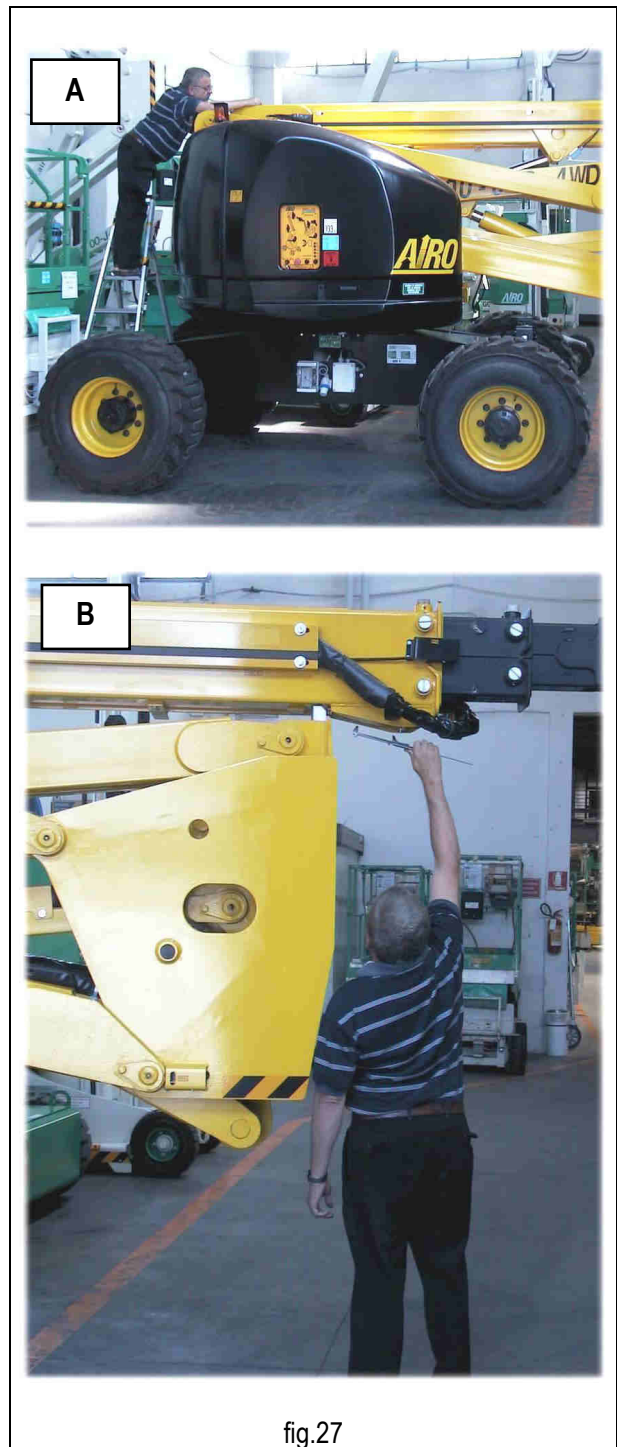

fig.27



**WARNING!**  
**AS THIS OPERATION IS VERY IMPORTANT IT IS TO BE CARRIED OUT BY SKILLED TECHNICIANS ONLY.**



**AFTER 10 YEARS THE CHAINS MUST BE REPLACED COMPLETELY.**  
**THIS OPERATION IS TO BE CARRIED OUT BY AUTHORIZED TECHNICAL ASSISTANCE.**

### 7.2.11. Check/adjustment of tension of chains of telescopic boom extraction (A23 J only)

Every year check the tension of chains of the telescopic boom extraction.

The correct tension is achieved when the two telescopic deck extensions start simultaneously during extraction (or retraction).

Microswitches (M14 and M15) control the tension state of the chains.

Should it be necessary to tension the chains, proceed as follows:

- Unscrew the lock-nut.
- Screw in the adjusting nut until you get the desired tension.
- Once the tension has been adjusted, block the lock-nut.

To adjust the extension chains, extract the telescopic boom for about 1 metre, and carry out the above mentioned operations according to the position in the picture **A** of the previous page.

To adjust the re-entry chains, perform the operations described above, positioning as indicated in the figure **B** on the previous page.



**WARNING!**  
**AS THIS OPERATION IS VERY IMPORTANT IT IS TO BE CARRIED OUT BY SKILLED TECHNICIANS ONLY.**



**AFTER 10 YEARS THE CHAINS MUST BE REPLACED COMPLETELY. THIS OPERATION IS TO BE CARRIED OUT BY AUTHORIZED TECHNICAL ASSISTANCE.**



## 7.2.12. Circuit movements pressure relief valve operation check

The main pressure relief valve controls the maximum pressure of the circuit movements. (lifting operations/lowering/rotation). Normally, this valve does not require any adjustment, since it is calibrated at the factory before the machine is delivered.

The adjustment of the system is required:

- in case of replacement of the hydraulic block.
- in case of replacement of the pressure relief valve only.

Check operation at least once a year.

To check the operation of the pressure relief valve:

- Introduce a pressure gauge with full scale of at least 250 bar in the special quick coupling (1/4" BSP) **D**.
- Using the ground control panel lift the machine up to the end stop.
- Check the pressure value. The correct value is indicated in the chapter "**Technical features**".

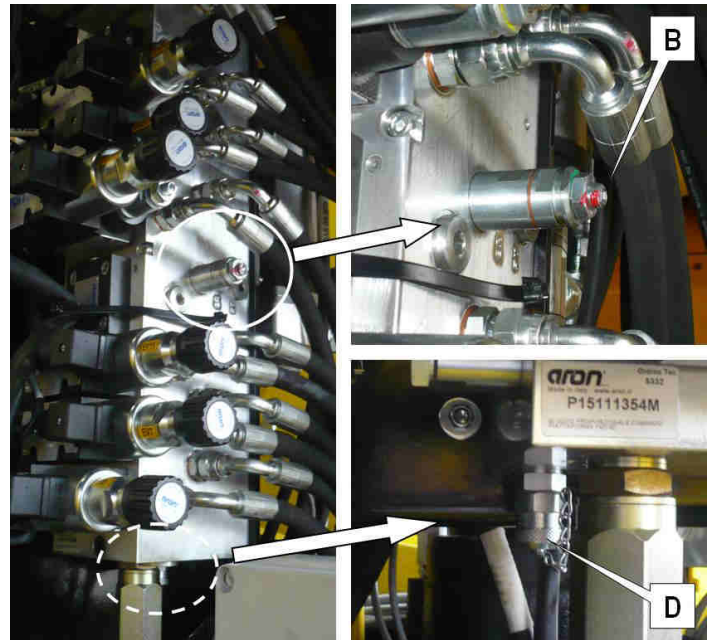

Fig. 28

To calibrate the pressure relief valve:

- Introduce a pressure gauge with full scale of at least 250 bar in the special quick coupling (1/4" BSP) **D**.
- Locate the pressure relief valve of lifting circuit **B**.
- Unscrew the adjusting dowel lock-nut.
- Using the ground control panel lift the machine up to the end stop.
- Adjust the pressure relief valve by means of the adjusting dowel so as to reach the pressure value indicated in chapter "**Technical Features**".
- Once calibration has been carried out, lock the adjusting dowel by means of the lock-nut.



**WARNING!**  
**AS THIS OPERATION IS VERY IMPORTANT IT IS TO BE CARRIED OUT BY SKILLED TECHNICIANS ONLY.**

### 7.2.13. Operation check of the turret inclinometer



#### WARNING!

Usually the inclinometer does not need to be adjusted unless the electronic control unit is replaced. The equipment necessary for the replacement and adjustment of this component is such that these operations should be carried out by skilled personnel.

**AS THIS OPERATION IS VERY IMPORTANT IT IS TO BE CARRIED OUT BY SKILLED TECHNICIANS ONLY.**

The inclinometer does not require any adjustment since it is calibrated in the factory before the machine is delivered. This device controls the chassis inclination and when inclined over the allowed value:

- It disables lifting.
- It disables drive when platform exceeds a given height (varying according to model).
- It warns of the instability condition by means of an audible alarm and a warning light located on the platform (see “General use instructions”).

The inclinometer checks the inclination with respect to the two axes (X; Y). On machine models that have the same transversal and longitudinal inclination limits, the control is carried out with reference to one axis only (X-axis).

#### Check operation at least once a year.

To check the inclinometer operation according to the **longitudinal axis** (generally **X-axis**):

- using the platform controls, set the machine so as to place a shim of dimension (**A+10 mm**) under the two rear or front wheels (see following table).
- wait three seconds (operation delay set at factory) until the danger red light turns on. With platform lowered (booms down, telescopic boom in and jib at a height between  $+10^\circ$  and  $-70^\circ$ ) all manoeuvres are still possible. By lifting one of the booms (excepting the Jib) and/or extracting the telescopic boom with respect to the horizontal, the audible alarm in platform is activated and the control system of the machine disables the lifting and drive controls.
- If the alarm does not go off **CALL THE TECHNICAL ASSISTANCE.**

To check the inclinometer according to the **transversal axis** (normally **Y-axis**):

- Using the platform control panel set the machine so as to place a shim of dimension (**B+10 mm**) under the two side right or left wheels (see following table).
- wait three seconds (operation delay set at factory) until the danger red light turns on. With platform lowered (booms down, telescopic boom in and jib at a height between  $+10^\circ$  and  $-70^\circ$ ) all manoeuvres are still possible. By lifting one of the booms (excepting the Jib) and/or extracting the telescopic boom with respect to the horizontal, the audible alarm in platform is activated and the control system of the machine disables the lifting and drive controls.

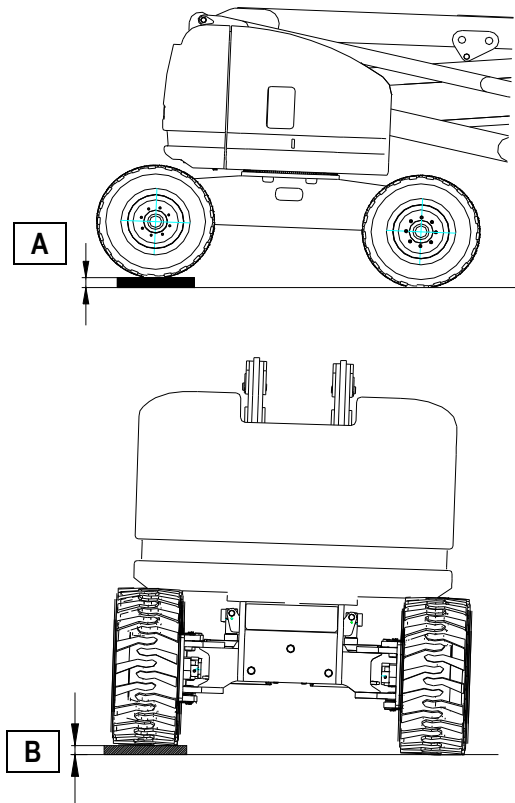
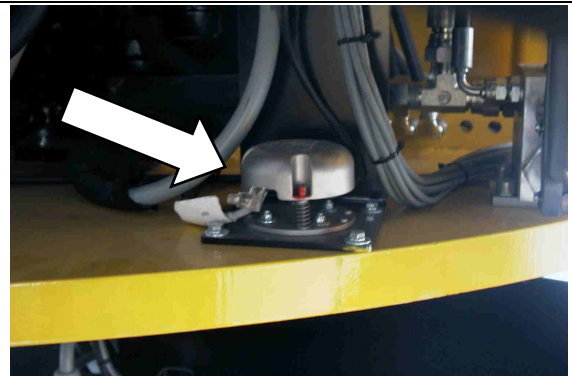

Fig.29

- If the alarm does not go off CALL THE TECHNICAL ASSISTANCE.

<b>MODELS</b>				
<b>SHIMS</b>	<b>A21 JRTD</b>	<b>A21 JRTE</b>	<b>A23 JRTD</b>	<b>A23 JRTE</b>
<b>A [mm]</b>	170	170	170	170
<b>B [mm]</b>	138	138	138	138



**WARNING!** The dimensions of shims A and B refer to max. allowed inclination as indicated in table "TECHNICAL FEATURES". To be used during the inclinometer calibration.

## 7.2.14. Operation check and adjustment of platform overload controller

The AIRO self-propelled articulated boom aerial platforms are equipped with a sophisticated overload controller.

Normally the overload controller does not require any adjustments, since it is calibrated in the factory before the machine is delivered.

This device checks the load on the platform and:

- Disables all movements if platform is overloaded by 20% compared to the nominal load (drive and steering disabled with platform lifted).
- With platform in transport position and overloaded by 20% compared to the nominal load, it disables lifting of the telescopic boom.
- Warns the user of the overload condition by means of the audible alarm and the platform warning light.
- By removing the exceeding load, the machine can be operated again.

Check operation at least once a year.

The overload controller consists of:

- Deformation transducer (A) (load cells).
- Electronic board (B) for the system calibration located inside a tight case (C) in platform.

Operation check of the overload controller:

- When the platform is completely lowered and with slide-out extension deck retracted, load a charge evenly distributed equal to the nominal load allowed by the platform (see paragraph "Technical features"). In this condition all manoeuvres should be possible both on platform control panel and ground control panel.
- When platform is completely lowered add to the rated load an overload of 25% of the nominal load. In this condition the red alarm light and the audible alarm turn on.
- If the platform is at a height from the ground higher than that indicated in chapter "Technical features" (the jib activates its microswitch after exceeding a height of 10° according to the horizontal axis), the alarm condition blocks the machine completely. To operate the machine again, remove the excessive load.

The system calibration is required:

- In case of replacement of one of the items composing the system.
- When, following an excessive overload or a collision, without the excessive load the danger condition is signalled anyway.

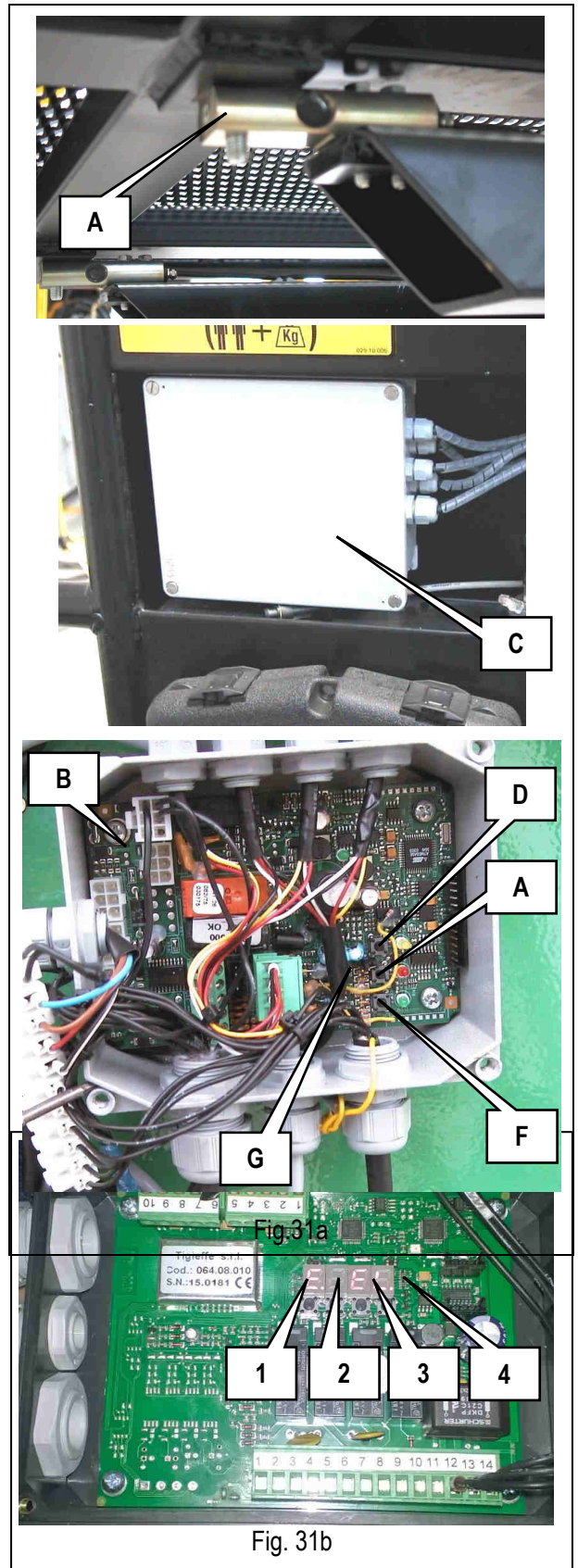

Fig. 31b

Calibration depends on the type of fitted device.

If the board is the one shown in **fig.31a**:

- Switch off the machine.
- Open the box which contains electronic board **C**.
- Without any load on the platform, fit the bridge between the two pins of the connector **G**.
- Switch on the machine.
- Press button **D** (the yellow light and red light turn on).
- Press button **E** (the luminosity of the red light increases a few seconds), and the overload controller will be reset.
- Position a distributed load on the platform equal to nominal capacity plus 20%.
- Press button **F** (the green light turns on a few seconds) to store the overload condition.
- Press button **D** again to exit the calibration procedure (the yellow light turns off and if the procedure has been carried out correctly, the red light stays on signalling the overload).
- Switch off the machine.
- Open the jumper on connector **G**.
- Switch on the machine.
- Check that after removing the 20% overload (only the rated load remains on the platform) the alarm condition does not occur in any of the platform positions (platform down, up, driving, rotated).
- Once the adjustment has been completed, close the box which contains the board.

If the board is the one shown in **fig.31b**:

- Switch off the machine.
- Open the box which contains electronic board.
- Switch on the machine.
- With no load on the platform, press and hold buttons **1** and **4** until the word **CONS** appears.
- Press **4** to enter the **CAP** and **4** again to display the parameter value.
- Enter the correct value = **1000** via the button **1**, **2** and **3**. Press button **4** to save and exit.
- Press **2** and **2** again to switch to **J01J**, press **4** to display the parameter value.
- Enter the correct value = **1** via the button **1**, and **3**. Press button **4** to save and exit.
- Press **3** and **2** again to switch to **CALB**. Press **4** to switch to **CAL**.
- After checking that there are no loads on platform, press **1** to perform the zero calibration.
- Load the weight equal to the nominal load and check out the value shown on the display. If it is correct, press **4** to save and exit, otherwise press **2** and then, via buttons **1**, **2** and **3** manually enter the correct value. Press **4** and **4** again to go back to **CALB**.
- Press **2** and **2** again to switch to **ALAR**, then press **4** and **2** again to switch to **BLOC**.
- Press **4** to enter and then, via buttons **1**, **2** and **3**, enter the alarm value equal to the nominal load + the overload of 20%. Press **4** to save.
- Press **2** to go to **DIFF** and **4** again to enter. Set the value = **0040**, via buttons **1**, **2** and **3**, then **4** again to store.
- Press **2** to switch to **TEST** and **4** again to do the test. When **PASS** appears, press **3** three times to exit calibration.
- Check out if the display shows the value of the current load on the platform.
- Check out if with a load  $\geq$  the rated load + 20% overload, the system goes into overload alarm and that, by removing the 20% overload, the alarm condition disappears.
- Once the adjustment has been completed, close the box which contains the board.



**AS THIS OPERATION IS VERY IMPORTANT IT IS TO BE CARRIED OUT BY SKILLED TECHNICIANS ONLY**

### 7.2.15. Overload controller by-pass – ONLY FOR EMERGENCY OPERATIONS

In case of fault and impossibility to calibrate the device, a by-pass of the system is possible by means of locking key switch (A) under the control panel. Keep the locking key switch active for 5 seconds and release to get the BY-PASS condition.

**WARNING!!** IN THIS CONDITION THE MACHINE CAN CARRY OUT ANY OPERATION, THOUGH THE RED FLASHING LED AND THE AUDIBLE ALARM SIGNAL THE DANGER CONDITION. TURNING OFF THE MACHINE WILL RESET THE SYSTEM, AND UPON STARTING, THE OVERLOAD CONTROLLER OPERATES AGAIN SIGNALLING THE PREVIOUS OVERLOAD CONDITION. THIS OPERATION IS ALLOWED ONLY FOR EMERGENCY HANDLING OF THE MACHINE. DO NOT USE THE MACHINE IF THE OVERLOAD CONTROLLER IS NOT EFFICIENT.

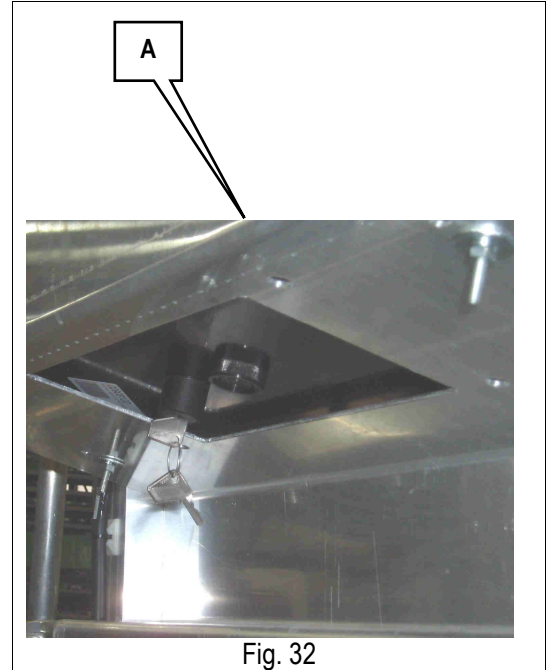

Fig. 32



**WARNING!**  
**THIS OPERATION IS ALLOWED ONLY FOR EMERGENCY HANDLING OF THE MACHINE OR IN THE EVENT OF A FAULT OR IMPOSSIBILITY TO CALIBRATE THE SYSTEM. DO NOT USE THE MACHINE IF THE OVERLOAD CONTROLLER IS NOT EFFICIENT.**



## 7.2.16. Operation check of M1 microswitches

The lifting booms and the telescopic extraction are controlled by microswitches:

- M1A on the pantograph.
- M1B on the boom.
- M1C on the Jib.
- M1D on the telescopic extraction.

Once a year check the working conditions of the microswitches M1.

The functions of the microswitches M1A- M1B- M1BB are the following:

with platform not in rest position (at least one of the microswitches M1A-M1B-M1BB is activated):

- The safety drive speed is automatically activated.
- If the chassis is inclined over the max. allowed inclination, lifting extension and drive controls are stopped.
- The compensation control for platform levelling is disabled.
- If the oscillating axle (if available) is not aligned with the fixed axle drive is stopped.
- When the platform is overloaded ALL operations until removal of overload are disabled.

The functions of the microswitch M1C on the Jib have been designed to favour loading/unloading operations from the ramps of a vehicle. With booms in rest position (microswitches M1A-M1B-M1BB not activated), and Jib with inclination higher than +10° according to the horizontal axis (M1C activated):

- The first drive speed is automatically activated.
- If the chassis is inclined over the max. allowed inclination, Jib lifting and drive controls remain allowed.

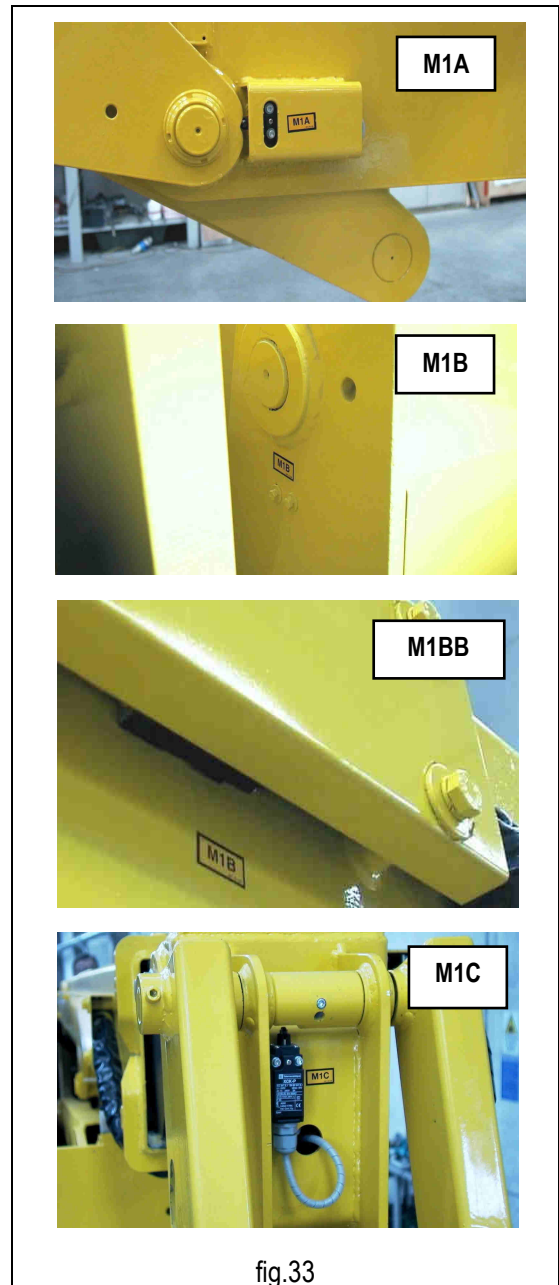

fig.33

### 7.2.17. Operation check of microswitch M9 (OPTIONAL)

The position of the swinging turret with respect to the chassis can be controlled by the microswitch M9 (OPTIONAL).

This microswitch at the centre of the turret will allow the operator on board to have the drive and steer direction always consistent with the platform position. The operator on the platform control position will always have the direction of drive and steering consistent with his own position.

Once a year check the working conditions of the microswitch M9.

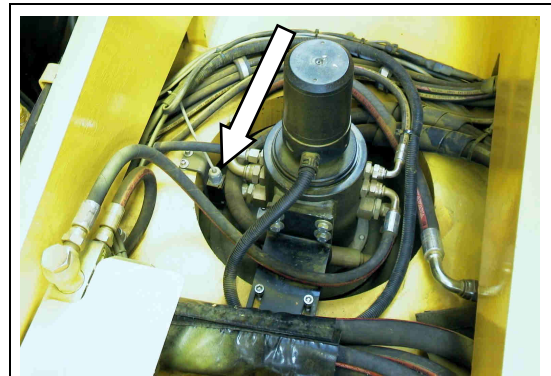

fig. 34



#### **WARNING!**

Be careful when the drive and steering controls match the  $\pm 90^\circ$  turret rotation according to the drive direction; in this position pay attention before operating the drive and steering controls.

Due to the possibility of performing simultaneously the controls of drive/steering and turret rotation (only with lowered boom), the reverse of drive/steering controls once the exchange point has been overcome takes place upon release of steering and drive controls.

### 7.2.18. Operation check of microswitch and proximity sensor M10

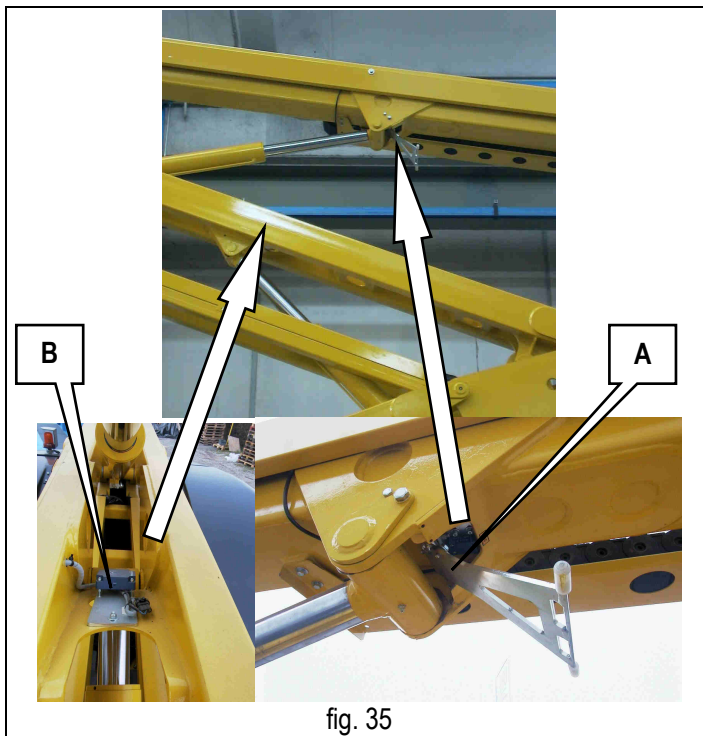

fig. 35

The microswitch (A) and the proximity sensor (B) M10 on the second boom of the scissors check the interference between the scissors and telescopic boom.

In case of interference between pantograph and telescopic boom the microswitch M10, by means of special levers, stops and stops the following operations:

- Pantograph lowering.
- Telescopic boom lowering.

The microswitch and proximity sensor perform the same function.

Once a year check the working conditions of the microswitch M10.



In the event that interference between pantograph and telescopic boom occurs in conditions of chassis instability (danger red light and alarm ON – lifting operations are stopped) the system allows the telescopic boom to be lifted gradually in order to – together with the pantograph lowering – recover the platform up to idle condition.



### 7.2.19. Operation check of proximity sensors M11 and M12 (OPTIONAL)

The proximity sensors M11 and M12 (OPTIONAL) control the positioning of the 4 steering wheels (OPTIONAL). The presence of the sensors M11 and M12 is tied to the option "4WS". The sensors are located:

- One on the front steering axle.
- One on the rear steering axle.

Their function is:

- To locate the point of "rear straight wheels" controlled by the operator on the platform.

Once a year check the working conditions of the sensors M11 – M12.

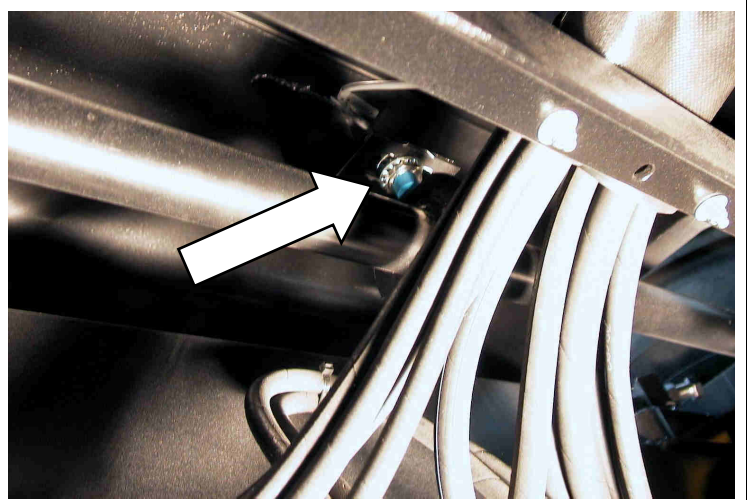

fig. 36

### 7.2.20. Operation check of proximity sensor M13 (OPTIONAL)

The proximity sensor checks the position of the oscillating axle (OPTIONAL) and is located on the chassis, above the oscillating axle.

Its function is:

- When the platform is lifted (the oscillating axle locks in the position it was before lifting) if the two wheels of the oscillating axle are not on the same ideal plane as those of the fixed axle, drive is prevented (this condition is signalled by the danger red light at platform - the alarm is not activated).

Once a year check the working conditions of the sensor M13.

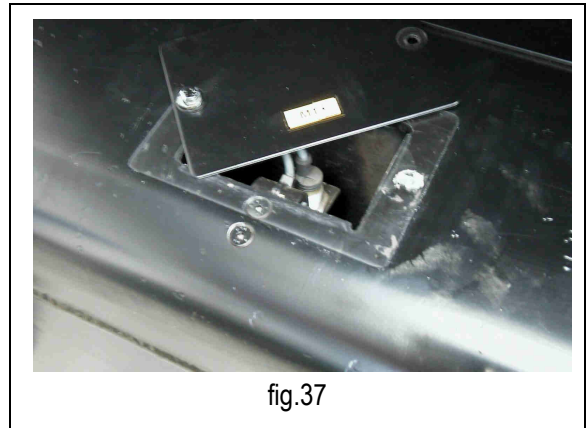

fig.37

### 7.2.21. Operation check of microswitches M14 and M15 (SG2100-J only)

The microswitches M14 and M15 control the tension of the chains of extraction (M14) and retraction (M15) of the telescopic boom.

If one or both checked chains are slackened:

- The operator on the platform is informed of the danger condition through a flashing red light of general danger (series of 3 flashes).
- With lowered platform, lifting of boom and pantograph and telescopic extraction/retraction are stopped but jib lifting is still allowed (EV18).
- With lifted platform, telescopic extraction/retraction is stopped to bring the platform to access position.

Once a year check the working conditions of the sensors M14 and M15.

### 7.2.22. Operation check of dead-man pedal safety system

The platform dead-man pedal is for enabling the operation controls of the machine on the platform control panel.

Check operation at least once a year.

To check the dead-man PEDAL:

- Move the drive joystick forward and backward in sequence, WITHOUT PRESSING THE dead-man PEDAL.
- Check that the machine does not perform any movement.
  
- Hold down the dead-man pedal for more than 10 seconds.
- With the pedal pressed, move the joystick forward and backward in sequence.
- Check that the machine does not perform any movement.

If the device works properly, no machine movement is possible on the platform control panel unless you press the dead-man pedal beforehand. If this is pressed for more than 10 seconds and no operation is performed, all movements are disabled; to operate the machine again, release the dead-man pedal and press it again.

The condition of the switch is indicated by the green led in the platform:

- green led lit up steady                      control panel enabled
- green led lit up flashing                    control panel disabled

### 7.3. Starting battery

The battery is one of the most important elements of the machine. It is recommended to keep it in an efficient condition to increase its useful life, to avoid faults and to reduce the management costs of the machine.

#### 7.3.1. Starter battery models “D” “ED”

On machines with heat engine the starter battery is for:

- Powering the machine control circuits.
- Starting the heat engine.
- Powering the 12V electrical pump for emergency operations (if any).

#### 7.3.2. Starter type battery for models “E”

On machines with batteries the starter battery is for:

- Powering the control circuits of the machine.

#### 7.3.3. Starter battery maintenance

The starter battery does not require any special maintenance.

- Keep terminals clean by removing any oxidation residues.
- Check correct terminal tightening.

#### 7.3.4. Starter battery recharge

Starter batteries do not require any recharge.

During normal operation of the Diesel engine an alternator recharges the battery (machines “D”, “ED”). On machines featuring single-phase 230 V or three-phase 380 V electrical pump, the control system of the electrical pump keeps the ignition battery charged during operation in “electric mode”. On machines with battery a DC-DC converter keeps the starter battery charged.



**WARNING!**

Check the charge of the starter battery after carrying a lowering manoeuvre of the platform with the 12V emergency electrical pump (OPTIONAL).

## 7.4. “DRIVE” battery for models “E” and “ED”

The battery is one of the most important elements of the machine. It is recommended to keep it in an efficient condition to increase its useful life, to avoid faults and to reduce the management costs of the machine.

### 7.4.1. General instructions for DRIVE battery

- In case of new batteries do not wait for the flat battery warning before recharging; recharge batteries after 3 or 4 working hours for the first 4/5 times.
- In case of new batteries full performance is achieved after approx. ten cycles of discharge and charge.
- Charge the battery in airy rooms and open the caps to allow the outflow of gas.
- Do not use extension leads exceeding 5 metres to connect the battery charger to the mains.
- Use a cable of suitable section (min 3x2.5 mm<sup>2</sup>).
- Do not use rolled-up cables.
- Do not approach the battery with flames. Risk of deflagration due to the formation of explosive gases.
- Do not carry out temporary or irregular electric connections.
- The terminals must be tightened and without deposits. The cables must be provided with a good insulation.
- Keep the battery cleaned, dry and free of oxidation products by using antistatic cloths.
- Do not place tools or any other metal object on the battery.
- Check that the electrolyte level is 5-7 mm higher than the splash guard level.
- During charging operations check that the electrolyte temperature is not higher than 45°C max.
- If the machine is equipped with an automatic topping up device, follow the instructions described in the battery user manual carefully.

### 7.4.2. DRIVE battery maintenance

- For normal water operating conditions, water topping up is to be carried out every week.
- Top up using distilled or demineralized water.
- Top up after battery charging. The electrolyte level must be 5-7 mm higher than the splash guard level.
- For machines equipped with automatic topping up device, follow the instructions given in the battery user manual.
- Battery discharge must be stopped when 80% of the battery rated capacity has been used. An excessive and prolonged discharge irreversibly damages the battery. The machine is equipped with a device that, when the battery is discharged by 80%, lifting operations are disabled. The battery needs to be recharged. This condition is signalled by a flashing light of the relevant led on the platform control panel.
- Battery charge is to be carried out according to the instructions given in the next paragraphs.
- Keep caps and connections covered and dry. A careful cleaning allows electric insulation protection, good operation and useful life of the battery.
- In case of faulty operations due to the battery, avoid any direct intervention and call the Customer Service.
- When the machine is not being used the batteries will run down automatically (automatic discharge). To avoid the battery operation from being compromised charge it at least once a month. This has to be done even if the density values of the electrolyte are high.
- To limit the discharge of the battery during periods of inactivity, store the machine in environments where the temperature is below 30°C and press all the emergency buttons, including the main power button.

### 7.4.3. Battery charger: DRIVE battery recharge



**WARNING!**  
EXPLOSIVE gas is originated during battery charging process. Therefore, charging must take place in airy rooms where no risks of fire and explosion exist and in the presence of fire extinguishers.

Connect the battery charger to the power mains having all protections according to the current standards in force and with the following features:

- Power voltage 380V 380V (400V +/-15%) 50Hz/60Hz.
- Frequency 50÷60 Hz.
- Activated grounding line.
- Magneto-thermic switch and residual current device ("circuit breaker").

Moreover:

- Do not use extension leads exceeding 5 metres to connect the battery charger to the mains.
- Use a cable of suitable section (min 3x2.5 mm<sup>2</sup>).
- Do not use rolled-up cables.



**IT IS FORBIDDEN**  
Connection to mains that do not comply with the above mentioned features.  
Failure to comply with the a.m. instructions may cause incorrect functioning of the battery charger with consequent damages not covered by the warranty.



**WARNING!**  
After charging, when the battery charger is still connected, the electrolyte density values should range from 1.260 g/l to 1.270 g/l (at 25thC).

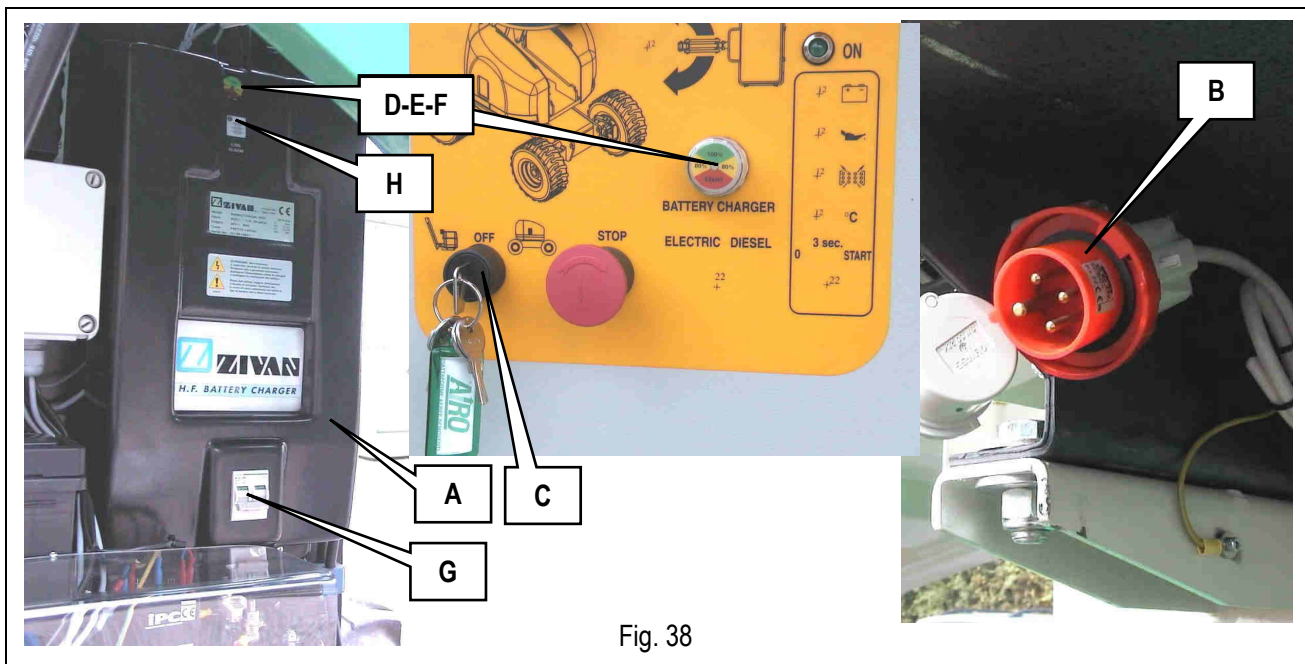

Fig. 38

To use the battery charger follow these procedures:

- Connect the battery charger by means of plug **B** to a current socket with the a.m. features.
- Set the switch on the battery charger (**G**) to ON position.

- Set the on-off switch **C** of the ground control station to OFF position (machine off), checking battery charger connection by means of LED **D** (red) (if it is on, connection is on-line).
- If led **E** (yellow) lights up, battery charger is approximately 80%.
- If led **F** (green) lights up, battery charge is over; the battery charger automatically turns off.

**WARNING! Light H turns on when a phase is missing in the power circuit. In this condition the battery charger does not work and the charge check indicator becomes yellow (check the power and inlet fuses).**

To disconnect the battery charger from the power source, disconnect the machine from the electric line.



**WARNING!**

**Before using the machine check that the power cord of the battery charger is disconnected.**

#### 7.4.4. Battery charger: fault report

An intermittent audible alarm and the flashing LED on the battery charger indicator described in the previous paragraph indicate that a warning situation has occurred:

Signalling	Alarm type	Problem description and troubleshooting
Alarm + flashing RED	Battery presence	Battery is disconnected or faulty (check connection and the rated voltage of the battery).
Alarm+ flashing YELLOW	Thermal probe	Thermal probe is disconnected during charging or outside working range (check probe connection and measure battery temperature).
Alarm+ flashing GREEN	Timeout	Phase 1 and/or Phase 2 of duration higher than the max. allowed value (check battery capacity).
Alarm+ flashing RED-YELLOW	Battery Current	Loss of output current control (fault in control logic).
Alarm+ flashing RED-GREEN	Battery Voltage	Loss of output voltage control (battery disconnected or fault in the control logic).
Alarm+ flashing RED-YELLOW-GREEN	Thermal	Over temperature of semiconductors (check the fan operation).



**WARNING!**

**In presence of alarm the battery charger stops the current delivery.**

#### 7.4.5. Battery replacement



**Replace the old batteries only with models of the same voltage, capacity, dimensions and mass. Batteries must be approved by the manufacturer.**



**Do not dispose of batteries in the environment after replacement. Comply with the current local standards.**



**AS THIS OPERATION IS VERY IMPORTANT IT IS TO BE CARRIED OUT BY SKILLED TECHNICIANS ONLY.**

**CALL THE TECHNICAL SUPPORT**

## 8. MARKS AND CERTIFICATIONS

The models of self-propelled aerial platform described in this manual were subjected to the CE type test according to the Directive 2006/42/EC. The certification was issued by:

<p><b>ICE Spa</b> <b>Via Garibaldi, 20</b> <b>40011 Anzola Emilia – BO (Italy)</b></p>	
--	--

Test carrying out is shown by the above plate with CE mark applied on the machine and by the declaration of conformity enclosed in this user manual.



## STANDARD STICKERS CODES

	CODE	DESCRIPTION	QUANTITY
1	001.10.001	AIRO warnings plate	1
2	001.10.024	AIRO serial number plate	1
3	001.10.031	Towing hook sticker	4
4	001.10.057	General warnings sticker	1
5	001.10.059	Wheels tightening sticker	1
6	001.10.060	Lifting point sticker	4
7	001.10.088	Document holder sticker	1
8	001.10.150	"46"oil type sticker I-D-F-NL-B-G-PL	1
9	001.10.180	First check sticker	1
10	001.10.243	"Max. Load per wheel" sticker	4
11	001.10.259	IPAF emergency sticker	1
12	001.10.260	Symbol articulated no stopping sticker	2
13	010.10.010	Black-yellow line sticker <150X300>	4
14	029.10.006	230 KG capacity sticker	1
15	029.10.011	No fasten cage sticker	1
16	035.10.005	Manual emergency sticker	1
17	035.10.006	Emergency towing sticker	4
18	035.10.007	Safety belts coupling sticker	2
19	035.10.009	Turret lock device sticker	1
20*	008.10.020	Triangle hot parts sticker	1
21*	029.10.005	Fuel tank sticker	1
22*	029.10.016	Sound power level sticker 103 dB	1
23**	001.10.098	STOP sticker I-D-F-NL-B-GB	1
24**	001.10.242	Emergency stop button yellow sticker	1
25	001.10.175	AIRO pre-spaced yellow sticker <530x265>	2
26	035.10.023	Pre-spaced sticker A21 JRTE BLACK	2
	035.10.024	Pre-spaced sticker A21 JRTD BLACK	2
	036.10.007	Pre-spaced sticker A23 JRTD BLACK	2
	036.10.008	Pre-spaced sticker A23 JRTE BLACK	2
27***	045.10.010	(Optional) electric line plug sticker	1
28***	001.10.021	(Optional) ground symbol sticker	1
29***	001.10.244	(Optional) entrance bar black-yellow line sticker	1

\* Only DIESEL models

\*\* Only Electric models

\*\*\* optional features

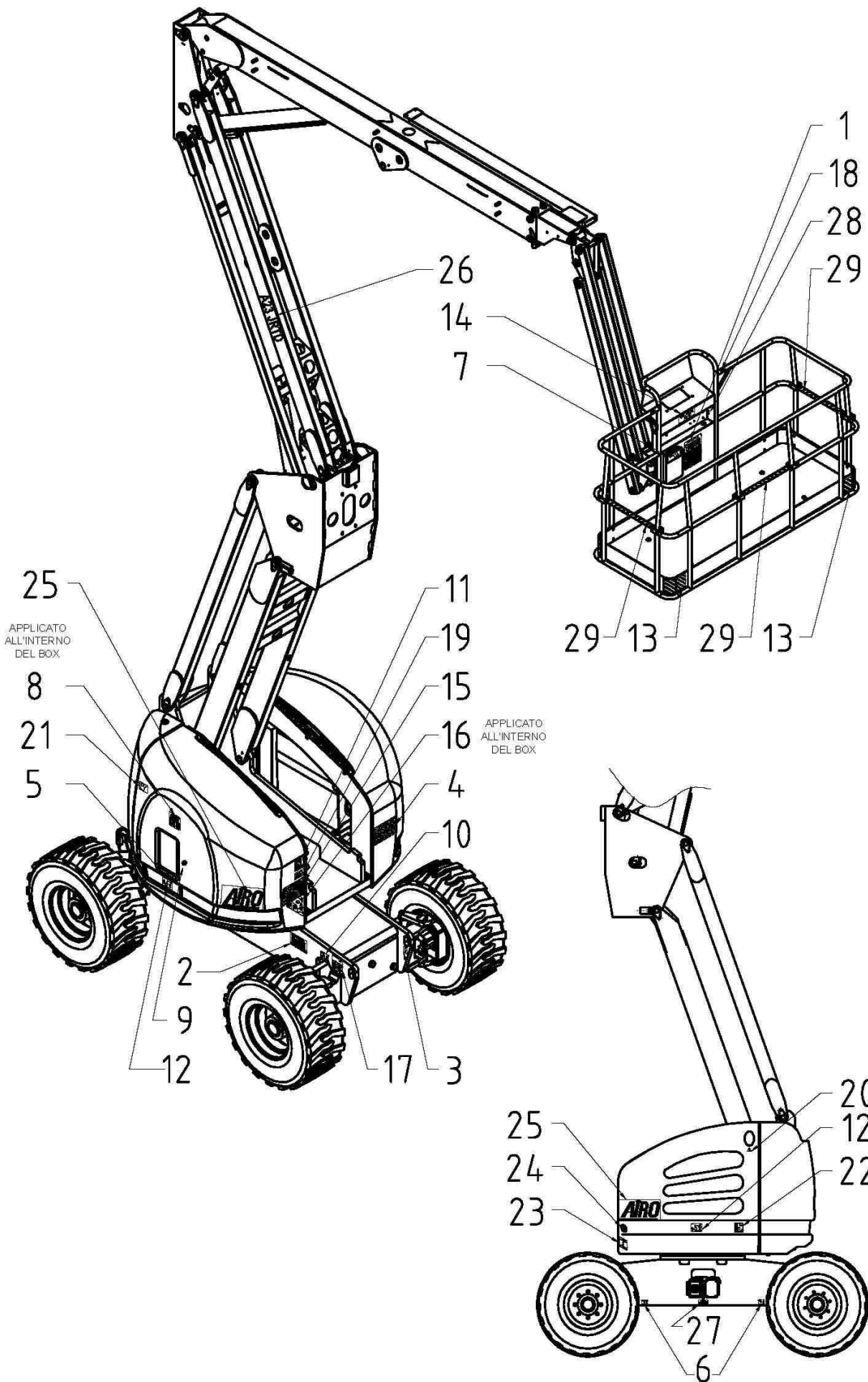

## 10 . CHECK REGISTER

The check register is released to the user of the platform in conformance with annex 1 of Directive 2006/42/EC. This register is to be considered an integral part of the equipment and must accompany the machine for its entire life until its final disposal.

The register is provided for the notation, according to the proposed format, of the following events that regard the life of the machine:

- Periodic obligatory inspections under the care of the agency responsible for checking it (in Italy, ASL or ARPA).
- Obligatory periodic inspections to verify the structure, proper machine functioning and the protection and safety systems. Such inspections are the responsibility of the safety manager of the company that owns the machine and must occur with **frequency indicated**.
- Transfers of ownership In Italy, the purchaser must notify the INAIL department responsible that the installation of the machine has occurred.
- Extraordinary maintenance work and replacement of important elements of the machine.

**REQUIRED PERIODIC INSPECTIONS BY THE REGULATORY AGENCY**

<b>Date</b>	<b>Observations</b>	<b>Signature + Stamp</b>

## REQUIRED PERIODIC INSPECTIONS BY THE OWNER

STRUCTURAL CHECK		DESCRIPTION OF OPERATIONS TO BE PERFORMED	
VISUAL CHECK		Check the integrity of the guardrails; the harness anchoring points; any access ladders; state of the lifting structure; rust; state of the tyres; oil leaks; locking pins on the structure.	
	DATE	REMARKS	SIGNATURE + STAMP
1st YEAR			
2nd YEAR			
3rd YEAR			
4th YEAR			
5th YEAR			
6th YEAR			
7th YEAR			
8th YEAR			
9th YEAR			
10th YEAR			
DEFORMATION OF TUBES AND CABLES		Most of all, check at junction points that tubes and cables do not show any evident defects. Monthly operation. It is not necessary to indicate its execution every month, but at least every year when the other operations are carried out.	
	DATE	REMARKS	SIGNATURE + STAMP
1st YEAR			
2nd YEAR			
3rd YEAR			
4th YEAR			
5th YEAR			
6th YEAR			
7th YEAR			
8th YEAR			
9th YEAR			
10th YEAR			

## REQUIRED PERIODIC INSPECTIONS BY THE OWNER

STRUCTURAL CHECK VARIOUS ADJUSTMENTS		DESCRIPTION OF OPERATIONS TO BE PERFORMED See chapter 7.2.1	
	DATE	REMARKS	SIGNATURE + STAMP
1st YEAR			
2nd YEAR			
3rd YEAR			
4th YEAR			
5th YEAR			
6th YEAR			
7th YEAR			
8th YEAR			
9th YEAR			
10th YEAR			

GREASING		See chapter 7.2.2 Monthly operation. It is not necessary to indicate its execution every month, but at least every year when the other operations are carried out.	
	DATE	REMARKS	SIGNATURE + STAMP
1st YEAR			
2nd YEAR			
3rd YEAR			
4th YEAR			
5th YEAR			
6th YEAR			
7th YEAR			
8th YEAR			
9th YEAR			
10th YEAR			

## REQUIRED PERIODIC INSPECTIONS BY THE OWNER

CHECK		DESCRIPTION OF OPERATIONS TO BE PERFORMED	
HYDRAULIC TANK OIL LEVEL CHECK		See chapter 7.2.3. Daily operation. It is not necessary to indicate its execution every day, but at least every year when the other operations are carried out.	
	DATE	REMARKS	SIGNATURE + STAMP
1st YEAR			
2nd YEAR			
3rd YEAR			
4th YEAR			
5th YEAR			
6th YEAR			
7th YEAR			
8th YEAR			
9th YEAR			
10th YEAR			
CHECK OF DRIVE AND ROTATION REDUCTION GEAR OIL CHANGE		See chapter 7.2.5 and 7.2.6	
	DATE	REMARKS	SIGNATURE + STAMP
1st YEAR			
2nd YEAR			
3rd YEAR			
4th YEAR			
5th YEAR			
6th YEAR			
7th YEAR			
8th YEAR			
9th YEAR			
10th YEAR			

## REQUIRED PERIODIC INSPECTIONS BY THE OWNER

CHECK		DESCRIPTION OF OPERATIONS TO BE PERFORMED	
CALIBRATION CHECK OF MOVEMENT CIRCUIT RELIEF PRESSURE VALVE		See chapter 7.2.12	
	DATE	REMARKS	SIGNATURE + STAMP
1st YEAR			
2nd YEAR			
3rd YEAR			
4th YEAR			
5th YEAR			
6th YEAR			
7th YEAR			
8th YEAR			
9th YEAR			
10th YEAR			
CLEARANCE ADJUSTMENT TURRET ROTATION		See chapter 7.2.8.	
	DATE	REMARKS	SIGNATURE + STAMP
1st YEAR			
2nd YEAR			
3rd YEAR			
4th YEAR			
5th YEAR			
6th YEAR			
7th YEAR			
8th YEAR			
9th YEAR			
10th YEAR			



## REQUIRED PERIODIC INSPECTIONS BY THE OWNER

CHECK		DESCRIPTION OF OPERATIONS TO BE PERFORMED	
BATTERY STATE		See chapter 7.3 and 7.4. Daily operation. It is not necessary to indicate its execution every day, but at least every year when the other operations are carried out.	
	DATE	REMARKS	SIGNATURE + STAMP
1st YEAR			
2nd YEAR			
3rd YEAR			
4th YEAR			
5th YEAR			
6th YEAR			
7th YEAR			
8th YEAR			
9th YEAR			
10th YEAR			
TELESCOPIC BOOM SLIDING BLOCKS CLEARANCE ADJUSTMENT		See chapter 7.2.9.	
	DATE	REMARKS	SIGNATURE + STAMP
1st YEAR			
2nd YEAR			
3rd YEAR			
4th YEAR			
5th YEAR			
6th YEAR			
7th YEAR			
8th YEAR			
9th YEAR			
10th YEAR			

## REQUIRED PERIODIC INSPECTIONS BY THE OWNER

CHECK		DESCRIPTION OF OPERATIONS TO BE PERFORMED	
TOTAL OIL CHANGE IN THE HYDRAULIC TANK FROM DRIVE AND ROTATION REDUCTION GEARS (EVERY TWO YEARS)		See chapters 7.2.3, 7.2.5, 7.2.6	
	DATE	REMARKS	SIGNATURE + STAMP
2nd YEAR			
4th YEAR			
6th YEAR			
8th YEAR			
10th YEAR			
HYDRAULIC FILTER REPLACING (EVERY TWO YEARS)		See chapter 7.2.4.	
	DATE	REMARKS	SIGNATURE + STAMP
2nd YEAR			
4th YEAR			
6th YEAR			
8th YEAR			
10th YEAR			

## REQUIRED PERIODIC INSPECTIONS BY THE OWNER

CHECK		DESCRIPTION OF OPERATIONS TO BE PERFORMED	
AIR PURGING FROM OSCILLATING AXLE CYLINDERS		See chapter 7.2.7.	
	DATE	REMARKS	SIGNATURE + STAMP
1st YEAR			
2nd YEAR			
3rd YEAR			
4th YEAR			
5th YEAR			
6th YEAR			
7th YEAR			
8th YEAR			
9th YEAR			
10th YEAR			

## REQUIRED PERIODIC INSPECTIONS BY THE OWNER

SAFETY SYSTEM CHECK		DESCRIPTION OF OPERATIONS TO BE PERFORMED	
OPERATION CHECK OF THE TURRET INCLINOMETER		See chapter 7.2.13	
	DATE	REMARKS	SIGNATURE + STAMP
1st YEAR			
2nd YEAR			
3rd YEAR			
4th YEAR			
5th YEAR			
6th YEAR			
7th YEAR			
8th YEAR			
9th YEAR			
10th YEAR			
OPERATION CHECK OF THE PLATFORM INCLINOMETER		Where it is present - optional	
	DATE	REMARKS	SIGNATURE + STAMP
1st YEAR			
2nd YEAR			
3rd YEAR			
4th YEAR			
5th YEAR			
6th YEAR			
7th YEAR			
8th YEAR			
9th YEAR			
10th YEAR			

## REQUIRED PERIODIC INSPECTIONS BY THE OWNER

SAFETY SYSTEM CHECK		DESCRIPTION OF OPERATIONS TO BE PERFORMED	
VISUAL CHECK OF WEAR CONDITION OF CHAINS OF BOOM EXTRACTION/BOOM RETRACTION (A23 J ONLY)		See chapter 7.2.10	
	DATE	REMARKS	SIGNATURE + STAMP
1st YEAR			
2nd YEAR			
3rd YEAR			
4th YEAR			
5th YEAR			
6th YEAR			
7th YEAR			
8th YEAR			
9th YEAR			
10th YEAR			
VISUAL CHECK OF WEAR CONDITION OF CHAINS OF BOOM EXTRACTION/BOOM RETRACTION (A23 J ONLY)		See chapter 7.2.11	
	DATE	REMARKS	SIGNATURE + STAMP
1st YEAR			
2nd YEAR			
3rd YEAR			
4th YEAR			
5th YEAR			
6th YEAR			
7th YEAR			
8th YEAR			
9th YEAR			
10th YEAR			

## REQUIRED PERIODIC INSPECTIONS BY THE OWNER

SAFETY SYSTEM CHECK		DESCRIPTION OF OPERATIONS TO BE PERFORMED	
EFFICIENCY CHECK OF PLATFORM OVERLOAD CONTROLLER		See chapter 7.2.14	
	DATE	REMARKS	SIGNATURE + STAMP
1st YEAR			
2nd YEAR			
3rd YEAR			
4th YEAR			
5th YEAR			
6th YEAR			
7th YEAR			
8th YEAR			
9th YEAR			
10th YEAR			
OPERATION CHECK MICROSWITCHES M1		See chapter 7.2.16	
	DATE	REMARKS	SIGNATURE + STAMP
1st YEAR			
2nd YEAR			
3rd YEAR			
4th YEAR			
5th YEAR			
6th YEAR			
7th YEAR			
8th YEAR			
9th YEAR			
10th YEAR			

## REQUIRED PERIODIC INSPECTIONS BY THE OWNER

SAFETY SYSTEM CHECK		DESCRIPTION OF OPERATIONS TO BE PERFORMED	
OPERATION CHECK MICROSWITCH M9		See chapter 7.2.17	
	DATE	REMARKS	SIGNATURE + STAMP
1st YEAR			
2nd YEAR			
3rd YEAR			
4th YEAR			
5th YEAR			
6th YEAR			
7th YEAR			
8th YEAR			
9th YEAR			
10th YEAR			

SAFETY SYSTEM CHECK		DESCRIPTION OF OPERATIONS TO BE PERFORMED	
OPERATION CHECK THE MICROSWITCH AND THE PROXIMITY SENSOR M10		See chapter 7.2.18	
	DATE	REMARKS	SIGNATURE + STAMP
1st YEAR			
2nd YEAR			
3rd YEAR			
4th YEAR			
5th YEAR			
6th YEAR			
7th YEAR			
8th YEAR			
9th YEAR			
10th YEAR			

## REQUIRED PERIODIC INSPECTIONS BY THE OWNER

SAFETY SYSTEM CHECK		DESCRIPTION OF OPERATIONS TO BE PERFORMED	
OPERATION CHECK PROXIMITY SENSOR M10 and M1"		See chapter 7.2.19	
	DATE	REMARKS	SIGNATURE + STAMP
1st YEAR			
2nd YEAR			
3rd YEAR			
4th YEAR			
5th YEAR			
6th YEAR			
7th YEAR			
8th YEAR			
9th YEAR			
10th YEAR			

SAFETY SYSTEM CHECK		DESCRIPTION OF OPERATIONS TO BE PERFORMED	
OPERATION CHECK PROXIMITY SENSOR M13		See chapter 7.2.20	
	DATE	REMARKS	SIGNATURE + STAMP
1st YEAR			
2nd YEAR			
3rd YEAR			
4th YEAR			
5th YEAR			
6th YEAR			
7th YEAR			
8th YEAR			
9th YEAR			
10th YEAR			



## REQUIRED PERIODIC INSPECTIONS BY THE OWNER

SAFETY SYSTEM CHECK		DESCRIPTION OF OPERATIONS TO BE PERFORMED	
OPERATION CHECK OPERATION CHECK OF MICROSWITCHES M15 AND M14 (A23 J ONLY)		See chapter 7.2.21	
	DATE	REMARKS	SIGNATURE + STAMP
1st YEAR			
2nd YEAR			
3rd YEAR			
4th YEAR			
5th YEAR			
6th YEAR			
7th YEAR			
8th YEAR			
9th YEAR			
10th YEAR			

SAFETY SYSTEM CHECK		DESCRIPTION OF OPERATIONS TO BE PERFORMED	
STICKERS AND PLATES CHECK		See Chapter 9. Check the legibility of the aluminium plate on the platform where the main instructions are summarised; that the capacity stickers are on the platform and that they are legible; that the stickers on the ground and platform controls are legible.	
	DATE		DATE
1st YEAR		1st YEAR	
2nd YEAR		2nd YEAR	
3rd YEAR		3rd YEAR	
4th YEAR		4th YEAR	
5th YEAR		5th YEAR	
6th YEAR		6th YEAR	
7th YEAR		7th YEAR	
8th YEAR		8th YEAR	
9th YEAR		9th YEAR	
10th YEAR		10th YEAR	

## REQUIRED PERIODIC INSPECTIONS BY THE OWNER

SAFETY SYSTEM CHECK		DESCRIPTION OF OPERATIONS TO BE PERFORMED	
DEAD-MAN SYSTEM CHECK		See chapter 7.2.22	
	DATE	REMARKS	SIGNATURE + STAMP
1st YEAR			
2nd YEAR			
3rd YEAR			
4th YEAR			
5th YEAR			
6th YEAR			
7th YEAR			
8th YEAR			
9th YEAR			
10th YEAR			

SAFETY SYSTEM CHECK		DESCRIPTION OF OPERATIONS TO BE PERFORMED	
BRAKING SYSTEM EFFICIENCY CHECK		GOING DOWN A RAMP WITH MAX. SLOPE INDICATED IN CHAPTER "TECHNICAL FEATURES", AT THE LOWEST SPEED, THE MACHINE SHOULD BE ABLE TO STOP, UPON RELEASE OF THE JOYSTICK, IN A SPACE OF LESS THAN 1.5 METERS	
	DATE	REMARKS	SIGNATURE + STAMP
1st YEAR			
2nd YEAR			
3rd YEAR			
4th YEAR			
5th YEAR			
6th YEAR			
7th YEAR			
8th YEAR			
9th YEAR			
10th YEAR			

## REQUIRED PERIODIC INSPECTIONS BY THE OWNER

CHECK OF EMERGENCY DEVICES		DESCRIPTION OF OPERATIONS TO BE PERFORMED	
MANUAL EMERGENCY LOWERING CHECK		See chapter 5.6	
	DATE	REMARKS	SIGNATURE + STAMP
1st YEAR			
2nd YEAR			
3rd YEAR			
4th YEAR			
5th YEAR			
6th YEAR			
7th YEAR			
8th YEAR			
9th YEAR			
10th YEAR			

## TRANSFERS OF OWNERSHIP

### FIRST OWNER

COMPANY	DATE	MODEL	SERIAL NUMBER	DELIVERY DATE

AIRO – Tigieffe S.r.l.

---

---

---

### SUBSEQUENT TRANSFERS OF OWNERSHIP

COMPANY	DATE

We affirm that, as of the date quoted above, the technical, dimensional and functional features of this machine were in conformance with what was originally required and that any changes have been recorded in this Register.

THE SELLER

THE PURCHASER

---

---

---

### SUBSEQUENT TRANSFERS OF OWNERSHIP

COMPANY	DATE

We affirm that, as of the date quoted above, the technical, dimensional and functional features of this machine were in conformance with what was originally required and that any changes have been recorded in this Register.

THE SELLER

THE PURCHASER

---

**SUBSEQUENT TRANSFERS OF OWNERSHIP**

COMPANY	DATE

We affirm that, as of the date quoted above, the technical, dimensional and functional features of this machine were in conformance with what was originally required and that any changes have been recorded in this Register.

**THE SELLER**

**THE PURCHASER**

---

---

**SUBSEQUENT TRANSFERS OF OWNERSHIP**

COMPANY	DATE

We affirm that, as of the date quoted above, the technical, dimensional and functional features of this machine were in conformance with what was originally required and that any changes have been recorded in this Register.

**THE SELLER**

**THE PURCHASER**

---

---

**SUBSEQUENT TRANSFERS OF OWNERSHIP**

COMPANY	DATE

We affirm that, as of the date quoted above, the technical, dimensional and functional features of this machine were in conformance with what was originally required and that any changes have been recorded in this Register.

**THE SELLER**

**THE PURCHASER**

---

## IMPORTANT BREAKDOWNS

DATE	DESCRIPTION OF BREAKDOWN	SOLUTION

SPARE PARTS USED		DESCRIPTION
CODE	QUANTITY	

SERVICE

SAFETY MANAGER

DATE	DESCRIPTION OF BREAKDOWN	SOLUTION

SPARE PARTS USED		DESCRIPTION
CODE	QUANTITY	

SERVICE

SAFETY MANAGER

## IMPORTANT BREAKDOWNS

DATE	DESCRIPTION OF BREAKDOWN	SOLUTION

SPARE PARTS USED		DESCRIPTION
CODE	QUANTITY	

SERVICE

SAFETY MANAGER

DATE	DESCRIPTION OF BREAKDOWN	SOLUTION

SPARE PARTS USED		DESCRIPTION
CODE	QUANTITY	

SERVICE

SAFETY MANAGER

## 11. WIRING DIAGRAMS

		Macchina / Machine →	A21 JRTD DIESEL 4WS - A23 JRTD DIESEL 4WS	A21 JRTD DIESEL 2WS - A23 JRTD DIESEL 2WS	A21 JRTE ELECTRIC 4WS - A23 JRTE ELECTRIC4 WS	A21 JRTE ELECTRIC 2WS - A23 JRTE ELECTRIC 2WS
Codice / Code		Descrizione / Description				
CHASSIS	035.08.028	4WS Chassis junction box - wired	X		X	
		4WS fixed structure derivation box - cabled				
	035.08.050	Chassis sheath 2WS		X		X
		2WS fixed structure Sheath				
	035.08.017	Circuit breaker case line 230V	X			
		Life-saver box				
TURRET	035.08.025	Turret junction box - wired	X			
		Turret derivation box - cabled				
	035.08.072	Turret junction box - wired			X	
		Turret derivation box - cabled				
THE ISUZU ENGINE	035.08.034	Heat engine junction box - wired	X			
		I.C.E. derivation box - Cabled				
HATZ ENGINE	035.08.069	Heat engine junction box - wired	X			
		I.C.E. derivation box - Cabled				
ELECTRIC MOTOR	035.08.053	Wired engine control case			X	
		Moter control box - cabled				
	035.08.068	Alim. sheath Motor field / fan			X	
		Fan and motr feed Sheath				
PLATFORM	035.08.024	Platform junction box - wired	X		X	
		Platform derivation box - cabled				



# 035.08.028

CAVO 24P+GV DA COLLETTORE ROTANTE (REALIZZAZIONE TIGIEFFE)  
24P+GV CABLE FROM ROTATING COLLECTOR

GUAINA ELETTROVALVOLE CARRO BASE COD.035.08.022 (DA FORNITORE)  
FIXED STRUCTURE ELECTRVALVES SHEATH COD.035.08.022

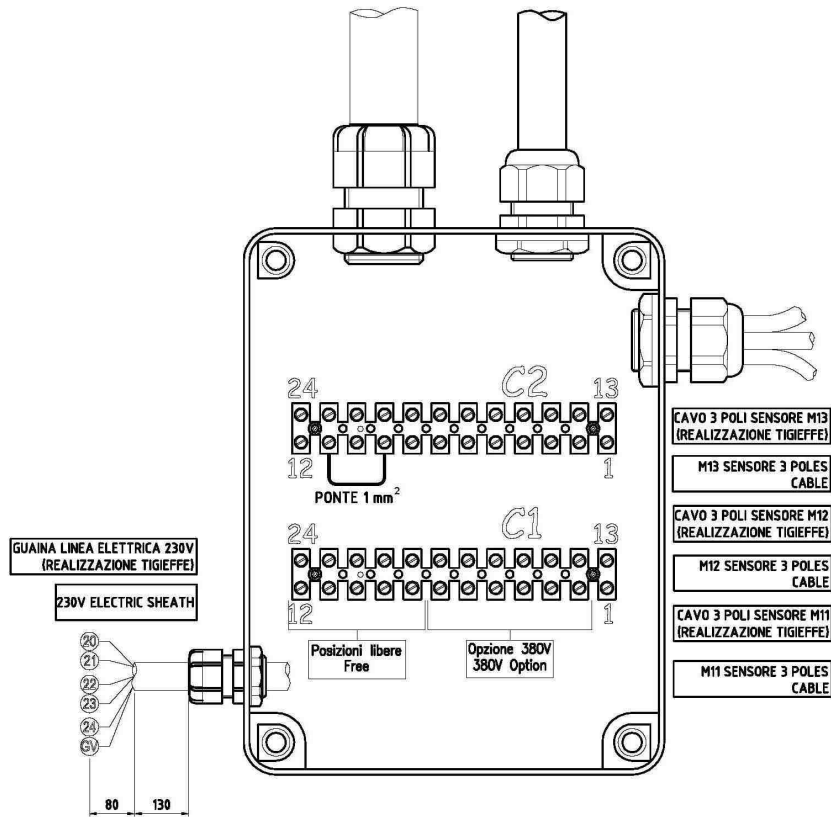

GUAINA ELETTROVALVOLE CARRO BASE COD. 035.08.022 (DA FORNITORE)			FIXED STRUCTURE ELECTRVALVES SHEATH COD.035.08.022		
N. FILO	PIN / CONNETT.	NOTE	WIRE N.	PIN / CONNECT.	NOTE
1	24 - C2	POSITIVO EV8	1	24 - C2	POSITIV EV8
2	23 - C2	NEGATIVO EV8	2	23 - C2	NEGATIV EV8
3	22 - C2	POSITIVO EV9	3	22 - C2	POSITIV EV9
4	23 - C2	NEGATIVO EV9	4	23 - C2	NEGATIV EV9
5	20 - C2	POSITIVO EV28	5	20 - C2	POSITIV EV28
6	23 - C2	NEGATIVO EV28	6	23 - C2	NEGATIV EV28
7	18 - C2	POSITIVO EV38	7	18 - C2	POSITIV EV38
8	21 - C2	NEGATIVO EV38	8	21 - C2	NEGATIV EV38
9	16 - C2	POSITIVO EV39	9	16 - C2	POSITIV EV39
10	21 - C2	NEGATIVO EV39	10	21 - C2	NEGATIV EV39
11	15 - C2	POSITIVO EV48	11	15 - C2	POSITIV EV48
12	21 - C2	NEGATIVO EV48	12	21 - C2	NEGATIV EV48
13	17 - C2	POSITIVO EV41	13	17 - C2	POSITIV EV41
14	23 - C2	NEGATIVO EV41	14	23 - C2	NEGATIV EV41
15		FILO LIBERO	15		FREE WIRE
16		FILO LIBERO	16		FREE WIRE

CAVO 24P+GV DA COLLETTORE ROTANTE (REALIZZAZIONE TIGIEFFE)			24P+GV CABLE FROM ROTATING COLLECTOR		
N. FILO	PIN / CONNETT.	NOTE	WIRE N.	PIN / CONNETT.	NOTE
1	12 - C2	POSITIVO EV8	1	12 - C2	POSITIV EV8
2	11 - C2	NEGATIVO EV8-28-41	2	11 - C2	NEGATIV EV8-28-41
3	10 - C2	POSITIVO EV9	3	10 - C2	POSITIV EV9
4	9 - C2	NEGATIVO EV28-38-48 M11-12-13	4	9 - C2	NEGATIV EV28-38-48 M11-12-13
5	8 - C2	POSITIVO EV28	5	8 - C2	POSITIV EV28
6	7 - C2	SEGNALE SENSORE M8	6	7 - C2	SIGNAL SENSOR M8
7	6 - C2	POSITIVO EV38	7	6 - C2	POSITIV EV38
8	5 - C2	POSITIVO EV41	8	5 - C2	POSITIV EV41
9	4 - C2	POSITIVO EV39	9	4 - C2	POSITIV EV39
10	3 - C2	POSITIVO EV29	10	3 - C2	POSITIV EV29
11	2 - C2	SEGNALE SENSORE M11	11	2 - C2	SIGNAL SENSOR M11
12	1 - C2	SEGNALE SENSORE M12	12	1 - C2	SIGNAL SENSOR M12
13	13 - C1	POSITIVO SENSORE M10-M12-M13	13	13 - C1	POSITIV SENSORS M10-M12-M13
14	14 - C1		14	14 - C1	
15	15 - C1		15	15 - C1	
16	16 - C1		16	16 - C1	
17	17 - C1		17	17 - C1	
18	18 - C1		18	18 - C1	
19	19 - C1		19	19 - C1	
20		FASE LINEA ELETTRICA 230V	20		230V ELECTRIC LINE FASE
21		FASE LINEA ELETTRICA 230V	21		230V ELECTRIC LINE FASE
22		NEUTRO LINEA ELETTRICA 230V	22		230V ELECTRIC LINE FASE
23		NEUTRO LINEA ELETTRICA 230V	23		230V ELECTRIC LINE FASE
24		TERRA LINEA ELETTRICA 230V	24		230V ELECTRIC LINE FASE
GV		TERRA LINEA ELETTRICA 230V	GV		230V ELECTRIC LINE FASE

CAVO SENSORE M11 - RUOTE STERZANTI POSTERIORI (REALIZZAZIONE TIGIEFFE)			M11 SENSOR CABLE - REAR STEERING WHEELS		
N. FILO	PIN / CONNETT.	NOTE	WIRE N.	PIN / CONNECT.	NOTE
MARRONE	1 - C1	POSITIVO M11-M12-M13	BROWN	1 - C1	POSITIV M11-M12-M13
NERO	14 - C2	SEGNALE M11	BLAKC	14 - C2	SIGNAL M11
BLU	21 - C2	NEGATIVO M11-M12-M13	BLUE	21 - C2	NEGATIV M11-M12-M13

CAVO SENSORE M12 - RUOTE STERZANTI ANTERIORI (REALIZZAZIONE TIGIEFFE)			M12 SENSOR CABLE - FRONT STEERING WHEELS		
N. FILO	PIN / CONNETT.	NOTE	WIRE N.	PIN / CONNECT.	NOTE
MARRONE	1 - C1	POSITIVO M11-M12-M13	BROWN	1 - C1	POSITIV M11-M12-M13
NERO	13 - C2	SEGNALE M12	BLAKC	13 - C2	SIGNAL M12
BLU	21 - C2	NEGATIVO M11-M12-M13	BLUE	21 - C2	NEGATIV M11-M12-M13

CAVO SENSORE M13 - ASSALE OSCILLANTE (REALIZZAZIONE TIGIEFFE)			M13 SENSOR CABLE - OSCILLATING AXLE		
N. FILO	PIN / CONNETT.	NOTE	WIRE N.	PIN / CONNETT.	NOTE
ROSSO	1 - C1	POSITIVO M11-M12-M13	RED	1 - C1	POSITIV M11-M12-M13
BIANCO	19 - C2	SEGNALE M13	WHITE	19 - C2	SIGNAL M13
NERO	21 - C2	NEGATIVO M11-M12-M13	BLAKC	21 - C2	NEGATIV M11-M12-M13

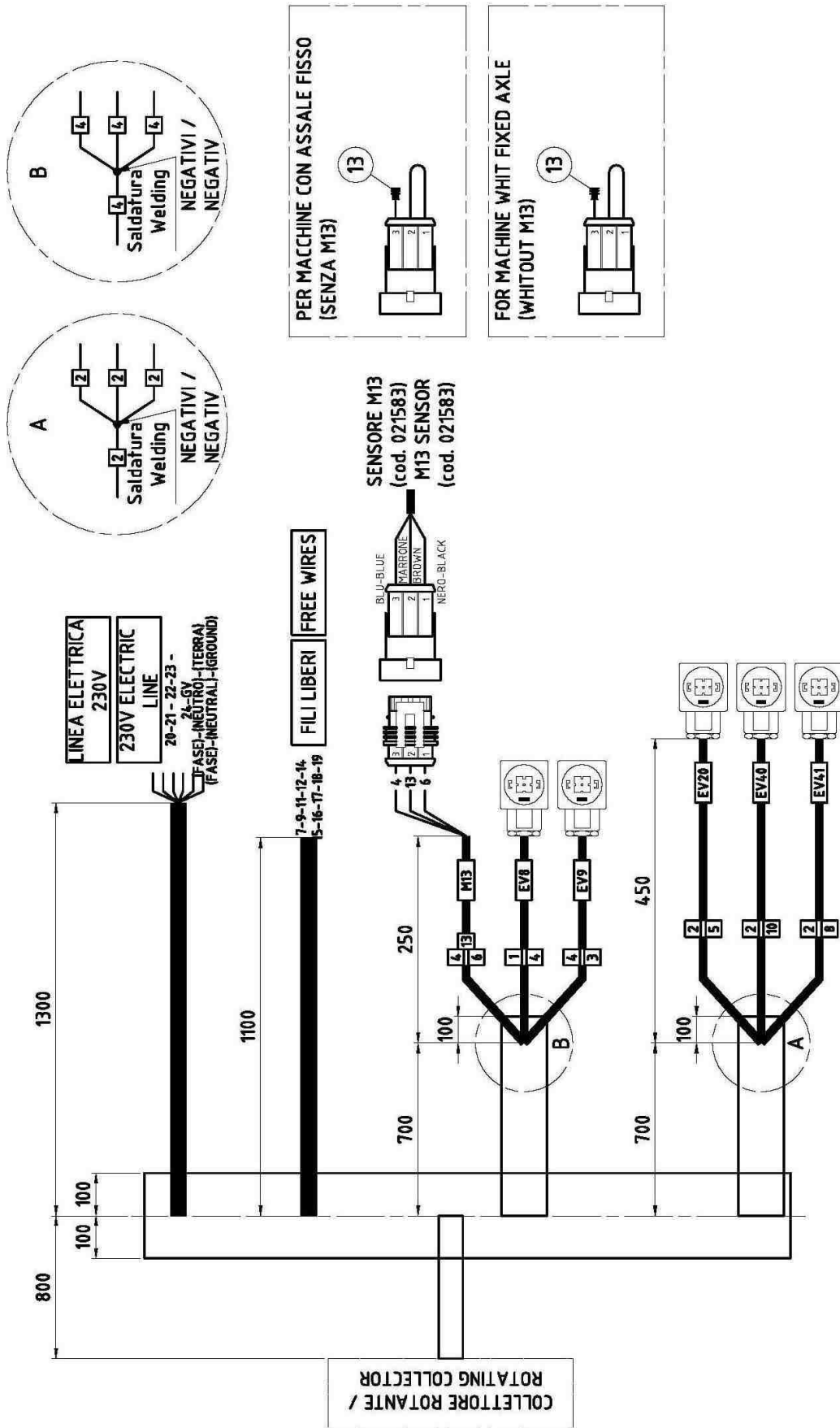

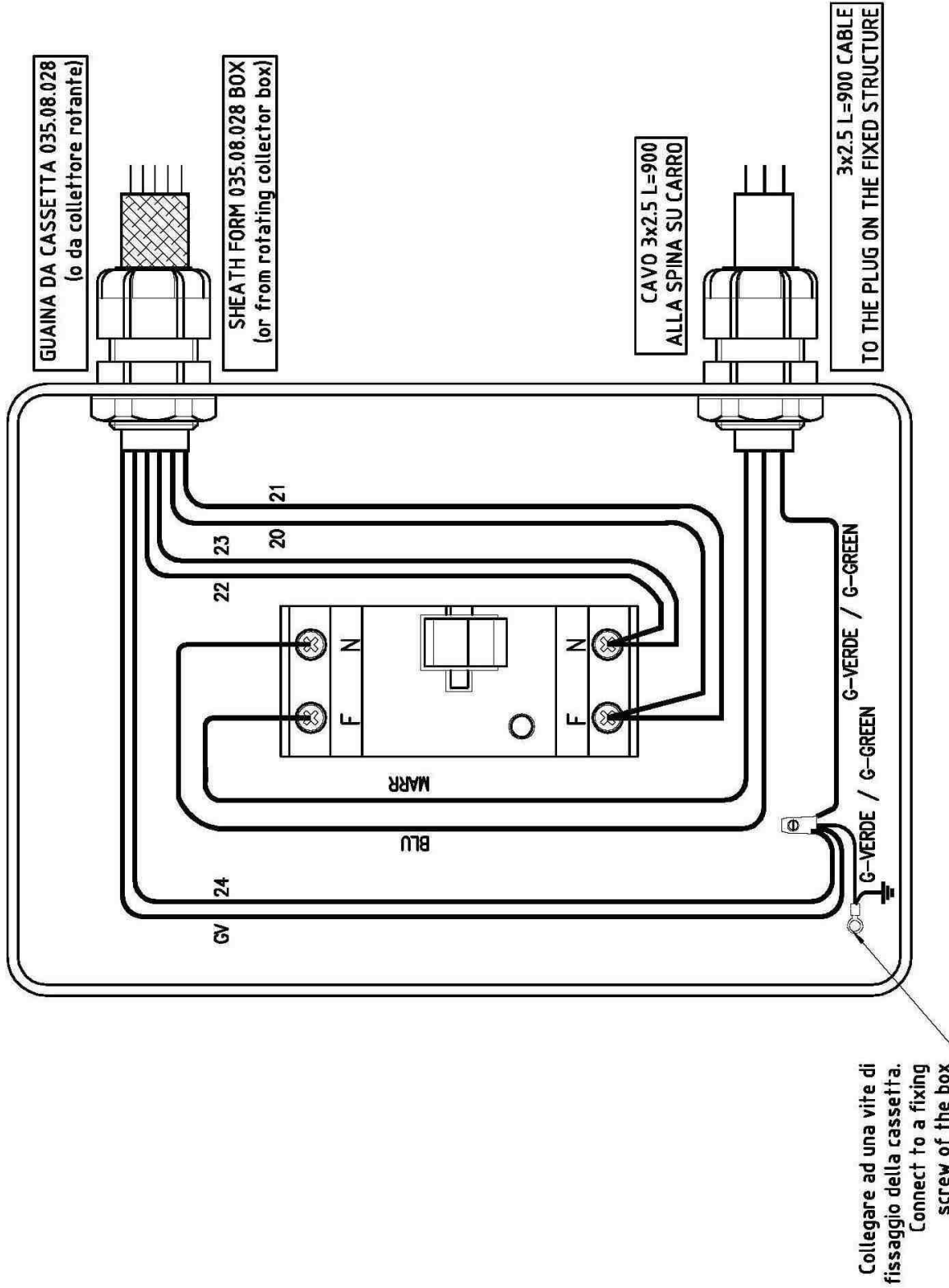

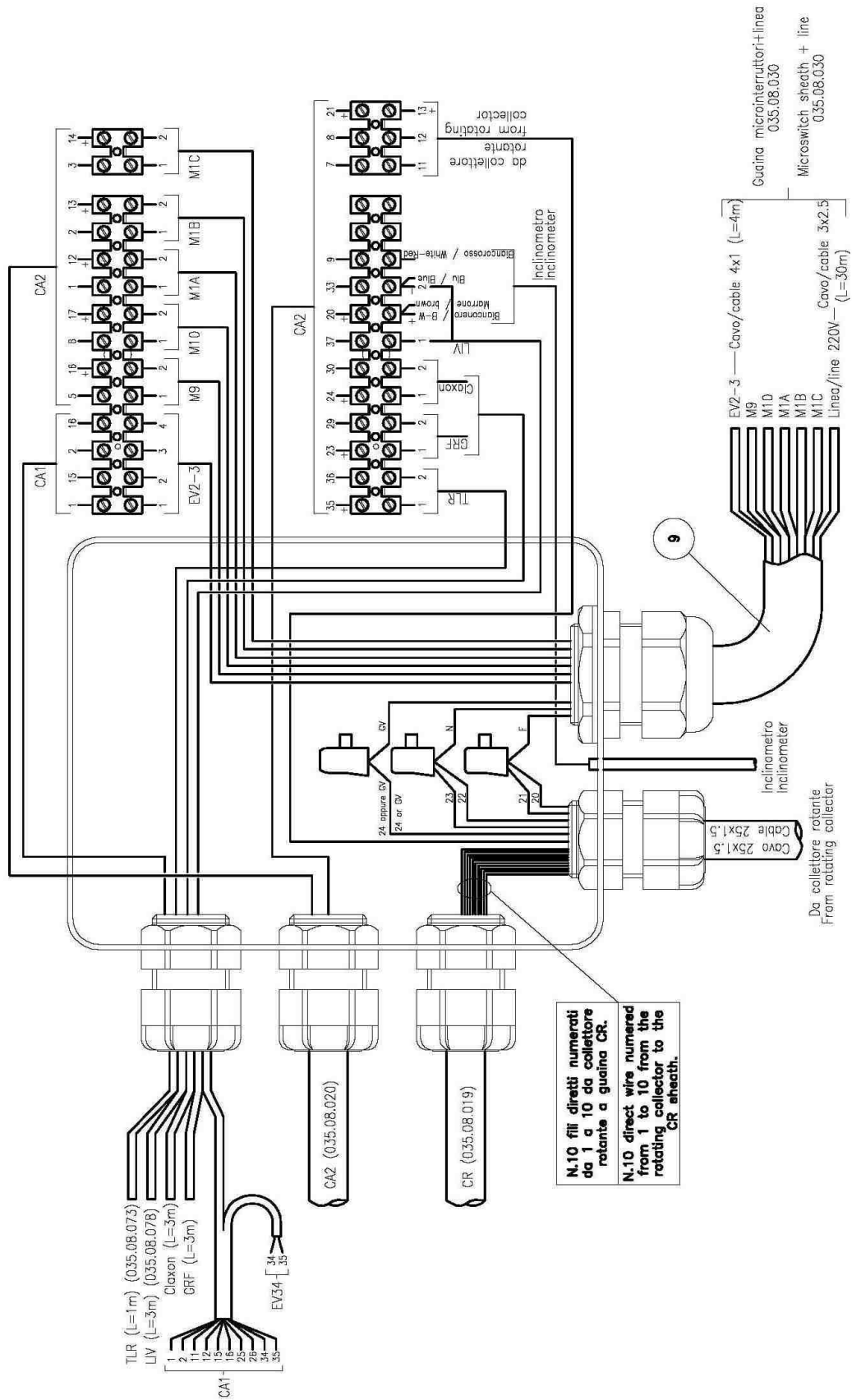

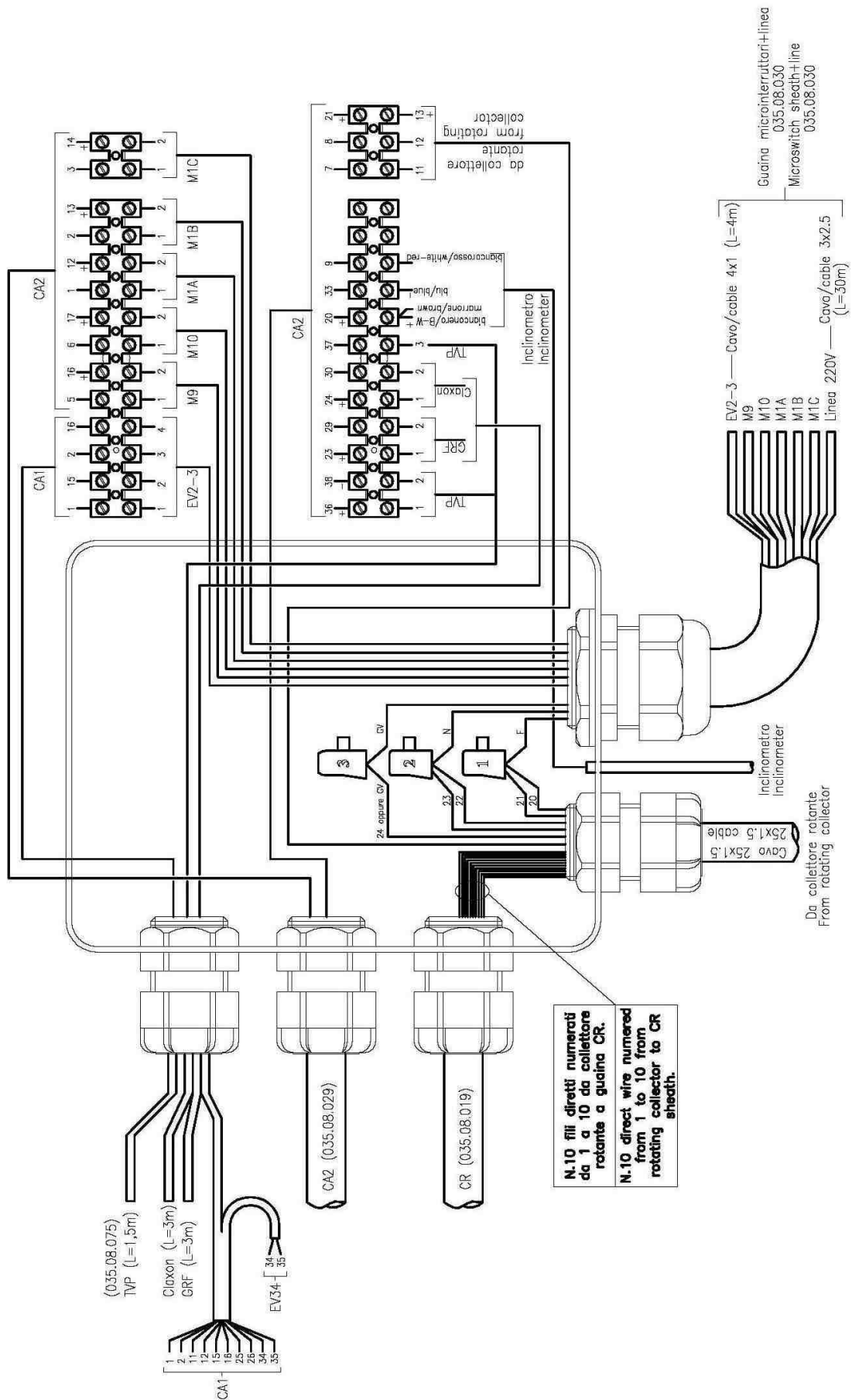

# 035.08.034

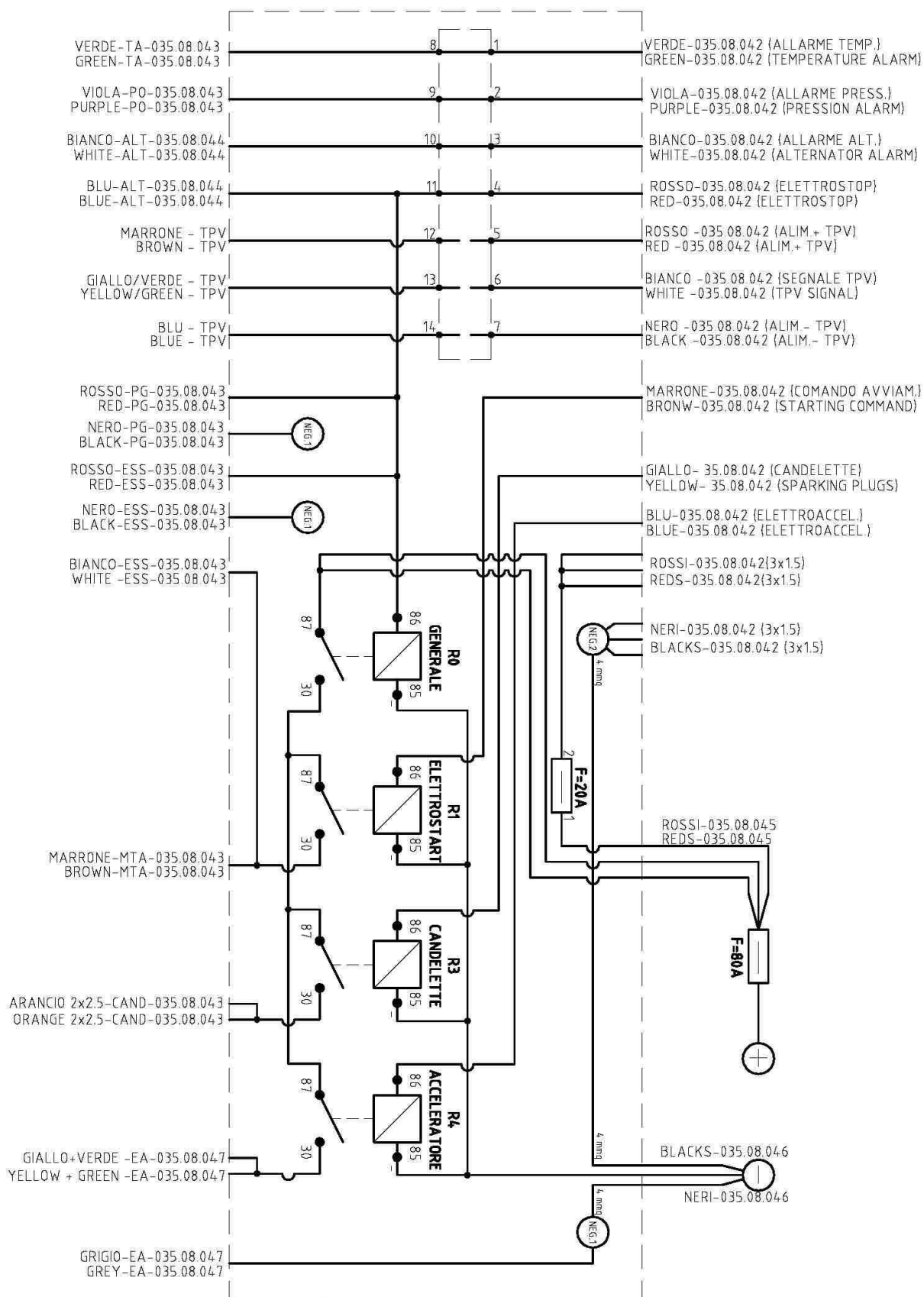

# 035.08.069

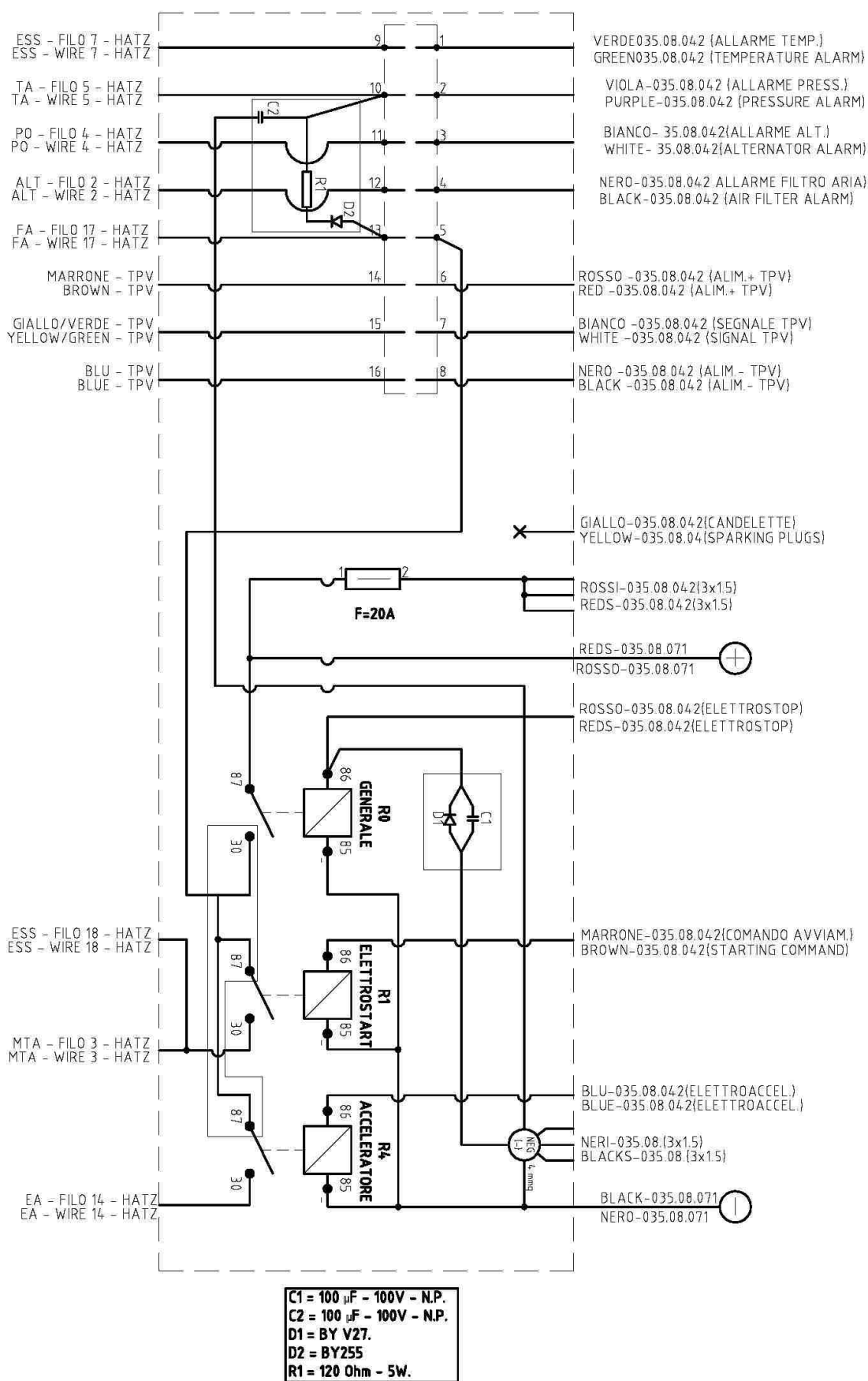

# 035.08.053

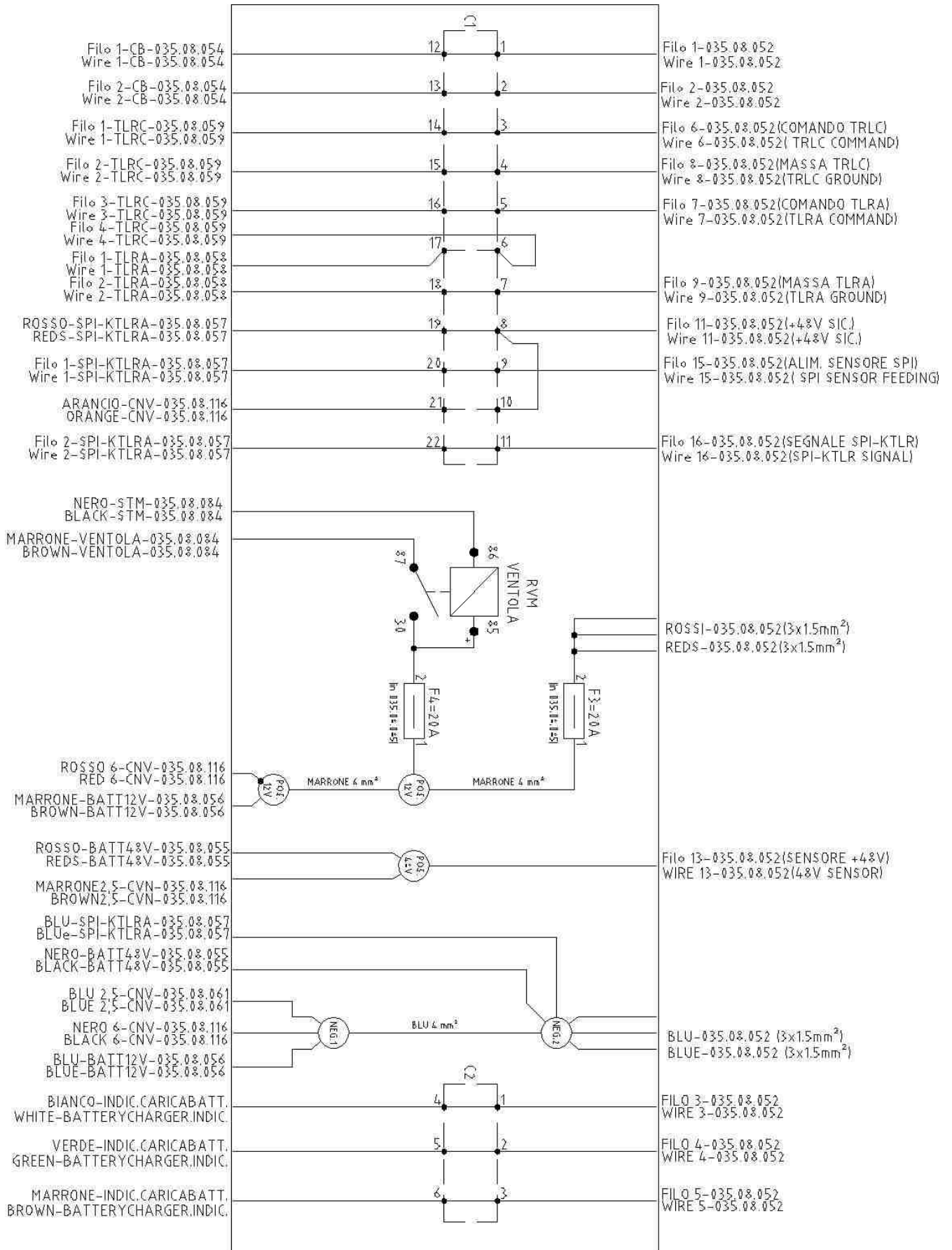



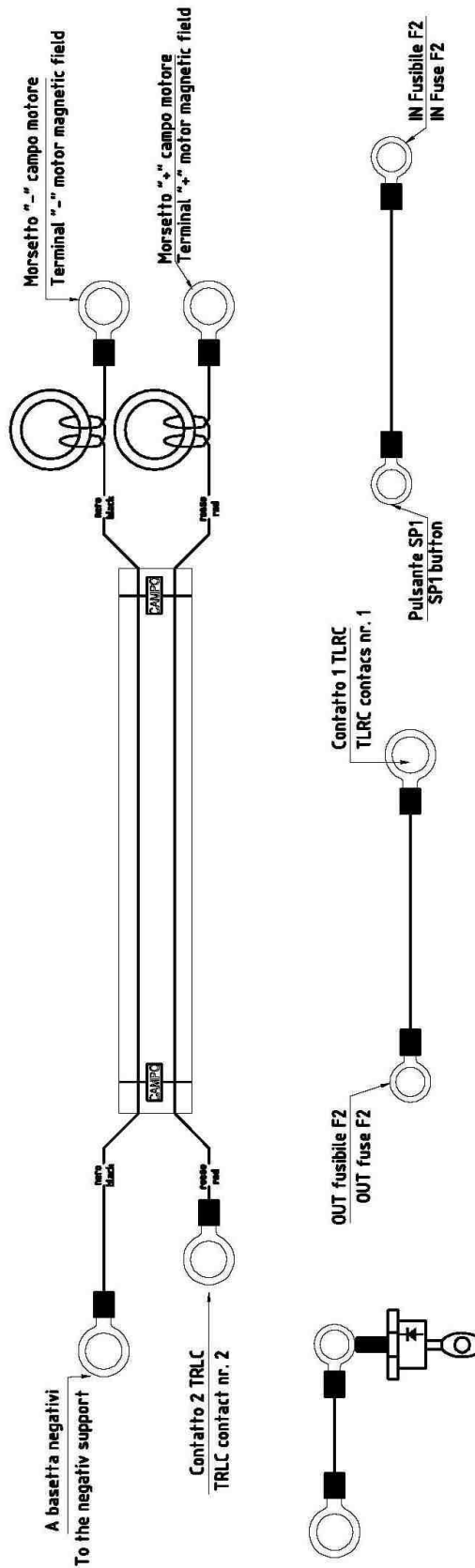

CAVO CELLA DI CARICO 1				LOAD CELL 1 CABLE			
N. FILO	PIN / CONNETT.	NOTE	WIRE N.	PIN / CONNECT.	NOTE	WIRE N.	PIN / CONNECT.
ROSSO	R - J7		RED	R - J7			
BIANCO		LIBERO	WHITE				FREE
GIALLO	G - J7		YELLOW	G - J7			FREE
NERO		LIBERO	BLACK				FREE

CAVO CELLA DI CARICO 2				LOAD CELL 2 CABLE			
N. FILO	PIN / CONNETT.	NOTE	WIRE N.	PIN / CONNECT.	NOTE	WIRE N.	PIN / CONNECT.
ROSSO		LIBERO	RED				FREE
BIANCO	B - J7		WHITE	B - J7			FREE
GIALLO		LIBERO	YELLOW				FREE
NERO	R - J7		BLACK	R - J7			FREE

CAVO CELLA DI CARICO 3				LOAD CELL 3 CABLE			
N. FILO	PIN / CONNETT.	NOTE	WIRE N.	PIN / CONNECT.	NOTE	WIRE N.	PIN / CONNECT.
ROSSO	N - J7		RED	N - J7			FREE
BIANCO		LIBERO	WHITE				FREE
GIALLO	B - J7		YELLOW	B - J7			FREE
NERO		LIBERO	BLACK				FREE

CAVO CELLA DI CARICO 4				LOAD CELL 4 CABLE			
N. FILO	PIN / CONNETT.	NOTE	WIRE N.	PIN / CONNECT.	NOTE	WIRE N.	PIN / CONNECT.
ROSSO		LIBERO	RED				FREE
BIANCO	G - J7		WHITE	G - J7			FREE
GIALLO		LIBERO	YELLOW				FREE
NERO	N - J7		BLACK	N - J7			FREE

CAVO PEDALE "UOMO PRESENTE"				"DEAD MAN" PEDAL CABLE			
N. FILO	PIN / CONNETT.	NOTE	WIRE N.	PIN / CONNECT.	NOTE	WIRE N.	PIN / CONNECT.
BLU	22 - C1	NEGATIVO "POC"	BLUE	22 - C1	"POC" NEGATIV		
MARRONE	21 - C1	POSITIVO "POC"	BROWN	21 - C1	"POC" POSITIV		
ROSSONERO	20 - C1	SEGNALE "PDE"	RED-BLACK	20 - C1	"POC" SIGNAL		
BIANCONERO	19 - C1	POSITIVO	B/W	19 - C1	POSITIV		

CAVO COMANDI DA TERRA COD.035.08.004				COMMAND CABLE FORM GROUND COD.035.08.004			
N. FILO	PIN / CONNETT.	NOTE	WIRE N.	PIN / CONNECT.	NOTE	WIRE N.	PIN / CONNECT.
1	13 - C1	TRASMISSIONE SERIALE (A)	1	13 - C1	SERIAL TRANSMISSION (A)		
2	14 - C1	TRASMISSIONE SERIALE (B)	2	14 - C1	SERIAL TRANSMISSION (B)		
3	15 - C1	TENSIONE BATTERIA DA FUSIBILE "F2"	3	15 - C1	BATTERY TENSION FROM FUSE "F2"		
4	16 - C1	NEGATIVO PRINCIPALE	4	16 - C1	MAIN NEGATIV		
5	17 - C1	PULSANTE A FUNGO	5	17 - C1	EMERGENCY STOP		
6	18 - C1	PULSANTE A FUNGO	6	18 - C1	EMERGENCY STOP		

CAVO COMANDI IN PIATTAFORMA COD.035.08.033				COMMAND CABLE FROM GROUND COD.035.08.033			
N. FILO	PIN / CONNETT.	NOTE	WIRE N.	PIN / CONNECT.	NOTE	WIRE N.	PIN / CONNECT.
1	1 - C1	TRASMISSIONE SERIALE (A)	1	1 - C1	SERIAL TRANSMISSION (A)		
2	2 - C1	TRASMISSIONE SERIALE (B)	2	2 - C1	SERIAL TRANSMISSION (B)		
3	3 - C1	TENSIONE BATTERIA DA FUSIBILE "F2"	3	3 - C1	BATTERY TENSION FROM FUSE "F2"		
4	4 - C1	NEGATIVO PRINCIPALE	4	4 - C1	MAIN NEGATIV		
5	5 - C1	PULSANTE A FUNGO	5	5 - C1	EMERGENCY STOP		
6	6 - C1	PULSANTE A FUNGO	6	6 - C1	EMERGENCY STOP		
7	7 - C1	USCITA POSITIVO PER "POC"	7	7 - C1	POSITIV EXIT FOR "POC"		
8	8 - C1	SEGNALE "POC"	8	8 - C1	"POC" SIGNAL		
9	1 - J5	ALIM POSITIVO SECONDA CELLE	9	1 - J5	CELL CARD POSITIV EXIT		
10	4 - J5	SEGNALE CELLE	10	4 - J5	CELL SIGNAL		
11	4 - J5	SEGNALE CELLE	11	4 - J5	CELL SIGNAL		
12	2 - J5	ALIM NEGATIVO SECONDA CELLE	12	2 - J5	CELL CARD NEGATIV EXIT		
13	11 - C1	POSITIVO PEDALE "UOMO PRESENTE"	13	11 - C1	"DEAD MAN" PEDAL POSITIV EXIT		
14	12 - C1	SEGNALE PEDALE "UOMO PRESENTE"	14	12 - C1	"DEAD MAN" PEDAL NEGATIV EXIT		
15	9 - C1	POSITIVO PRINCIPALE	15	9 - C1	"POC" NEGATIV		
16	10 - C1	NEGATIVO PRINCIPALE	16	10 - C1	"POC" NEGATIV		

CAVO PEDALE "UOMO PRESENTE"				"DEAD MAN" PEDAL CABLE			
N. FILO	PIN / CONNETT.	NOTE	WIRE N.	PIN / CONNECT.	NOTE	WIRE N.	PIN / CONNECT.
1 (o BLU)	24 - C1	POSITIVO	1 (or BLUE)	24 - C1	POSITIV		
2 (o MARRONE)	23 - C1	SEGNALE PEDALE	2 (or BROWN)	23 - C1	PEDAL SIGNAL		

035.08.024

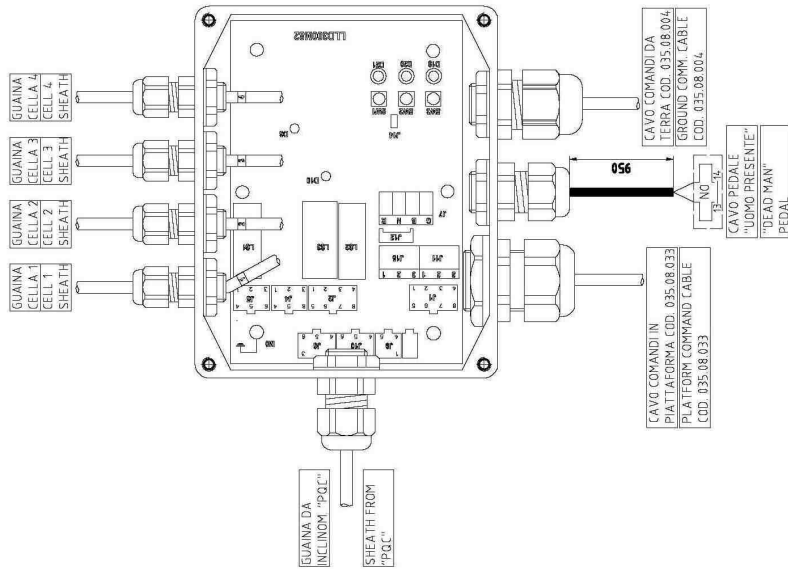

CAVO COMANDI DA TERRA COD.035.08.004			
N. FILO	PIN / CONNETT.	NOTE	
1	13 - C1	TRASMISSIONE SERIALE FEMALE	
2	14 - C1	TRASMISSIONE SERIALE MARRONE	
3	15 - C1	TENSIONE ALIMENTAZIONE DA FIDUCIE TP*	
4	16 - C1	RESISTIVO PRINCIPALE	
5	17 - C1	PULSANTE A PIANO	
6	18 - C1	PULSANTE A PIANO	

CAVO CELLA DI CARICO CANALE 1			
N. FILO	PIN / CONNETT.	NOTE	
CALZA	6 - SCHEDA		
BLU	7 - SCHEDA		
GIALLO	8 - SCHEDA		
VERDE	9 - SCHEDA		
ROSSO	10 - SCHEDA		

CAVO CELLA DI CARICO CANALE 2			
N. FILO	PIN / CONNETT.	NOTE	
CALZA	1 - SCHEDA		
BLU	2 - SCHEDA		
GIALLO	3 - SCHEDA		
VERDE	4 - SCHEDA		
ROSSO	5 - SCHEDA		

CONNETTORE 5pin SU SCHEDA COD. 035.08.121 (PER VERIFICA)			
N. PIN	N. FILO / GUAINA	NOTE	
1	Calza	Canale 2	
2	Blu	Canale 2	
3	Giallo	Canale 2	
4	Verde	Canale 2	
5	Rosso	Canale 2	

CONNETTORE 5pin SU SCHEDA COD. 035.08.121 (PER VERIFICA)			
N. PIN	N. FILO / GUAINA	NOTE	
6	Calza	Canale 1	
7	Blu	Canale 1	
8	Giallo	Canale 1	
9	Verde	Canale 1	
10	Rosso	Canale 1	

CONNETTORE C1			
N. PIN	N. FILO / GUAINA	NOTE	
1	10 - 035.08.033	SEGNALAZIONE SERIALE FEMALE	
2	11 - 035.08.033	SEGNALAZIONE SERIALE MARRONE	
3	12 - 035.08.033	ALIMENTAZIONE DA FIDUCIE TP*	
4	13 - 035.08.033	RESISTIVO PRINCIPALE	
5	14 - 035.08.033	PULSANTE A PIANO	

CONNETTORE C2* Optional (PER VERIFICA)			
N. PIN	N. FILO / GUAINA	NOTE	
1	17 - 035.08.033	Pulsante BHP	
2	18 - 035.08.033	Segnale BHP	
3	1 - BHP	Pin. cav. BHP	
4	2 - BHP	Supp. ALI BHP	

CONNETTORE "C1"			
N. PIN	N. FILO / GUAINA	NOTE	
1	1 - 035.08.033	TRASMISSIONE SERIALE FEMALE	
2	2 - 035.08.033	TRASMISSIONE SERIALE MARRONE	
3	3 - 035.08.033	TENSIONE ALIMENTAZIONE DA FIDUCIE TP*	
4	4 - 035.08.033	RESISTIVO PRINCIPALE	
5	5 - 035.08.033	PULSANTE A PIANO	
6	6 - 035.08.033	PULSANTE A PIANO	
7	7 - 035.08.033	ALIMENTAZIONE DA FIDUCIE TP*	
8	8 - 035.08.033	RESISTIVO PRINCIPALE	
9	9 - 035.08.033	PULSANTE A PIANO	
10	10 - 035.08.033	PULSANTE A PIANO	
11	11 - 035.08.033	SEGNALAZIONE SERIALE FEMALE	
12	12 - 035.08.033	SEGNALAZIONE SERIALE MARRONE	
13	13 - 035.08.004	TRASMISSIONE SERIALE BLU	
14	2 - 035.08.004	TENSIONE ALIMENTAZIONE DA FIDUCIE TP*	
15	3 - 035.08.004	RESISTIVO PRINCIPALE	
16	4 - 035.08.004	RESISTIVO PRINCIPALE	
17	5 - 035.08.004	PULSANTE A PIANO	
18	6 - 035.08.004	PULSANTE A PIANO	
19	BIANCONERO - POC	riservato	
20	ROSSONERO - POC	SEGNALAZIONE SERIALE FEMALE	
21	MARRONE - POC	riservato	
22	BLU - POC	RESISTIVO PRINCIPALE	
23	2 to MARRONEI - PEDALE	riservato	
24	1 to BLU - PEDALE	SEGNALAZIONE SERIALE FEMALE	

Scrivere sulle fascette identificative il numero della cella di carico corrispondente mediante pennarello indelebile.

1 2 3 4  
CONN. C2 (Opt.)

1 2 3 4  
CONNETTORE C1

1 2 3 4  
CONNETTORE C2\* Optional (PER VERIFICA)

CAVO PEDALE "UDIMO PRESENTE"

CAVO COMANDI IN PIATTAFORMA COD. 035.08.033

CAVO COMANDI DA TERRA COD. 035.08.004

CAVI "BHP" quando presente (montare PG in opera)

Inclinometro "POC" optional.  
Su impianto standard fare ponte tra pin 20 e 21 (C1)

## 12. HYDRAULIC DIAGRAM

No. 035.07.086

1-2	DRIVE MOTOR REDUCER
3	ROTATING DISTRIBUTOR
4	FILTER
5	QUICK COUPLING
6	FILLER CAP
7	COMBINED PUMP
8	FILTER
9	FILTER
10	MANUAL PUMP
11	EMERGENCY ELECTROPUMP
12	STEERING CYLINDER
13	STEERING HYDRAULIC BLOCK
14	SWING AXLE CYLINDER
15-18-22-29	OVER-CENTER VALVE
16	HYDRAULIC BLOCK STEERING SELECTION / MOVEMENTS
17	MOVEMENT SOLENOID VALVE BLOCK
19	SCISSOR CYLINDER
20	TELESCOPIC BOOM EXTENSION CYLINDER
21	BOOM CYLINDER
23	DRIVE PLATE
24	TURRET ROTATION GEARED MOTOR
25	ROTARY ACTUATOR WITH VALVE
26	JIB CYLINDER
27	SENSOR CYLINDER
28	PLATFORM LEVELLING CYLINDER
30	SELECTOR VALVE
31	PRESSURE TRANSDUCER
32-34-38	UNIDIRECTIONAL VALVE
33	380V ELECTRIC PUMP KIT
35	380V ELECTRIC PUMP
36	TAP
37	HYDRAULIC BLOCK SUCTION EXCHANGE / UNLOADING
M	DIESEL MOTOR
<b>EV2</b>	FORWARD DRIVE SOLENOID VALVE
<b>EV3</b>	BACKWARD DRIVE SOLENOID VALVE
<b>EV4</b>	SCISSOR LIFTING SOLENOID VALVE
<b>EV5</b>	SCISSOR LOWERING SOLENOID VALVE
<b>EV6</b>	BOOM EXTENSION SOLENOID VALVE
<b>EV7</b>	BOOM RETRACTION SOLENOID VALVE
<b>EV8</b>	RIGHT STEERING SOLENOID VALVE
<b>EV9</b>	LEFT STEERING SOLENOID VALVE
<b>EV12</b>	CLOCKWISE TURRET ROTATION SOLENOID VALVE
<b>EV13</b>	ANTICLOCKWISE TURRET ROTATION SOLENOID VALVE
<b>EV14</b>	BOOM LIFTING SOLENOID VALVE
<b>EV15</b>	BOOM LOWERING SOLENOID VALVE
<b>EV16</b>	FORWARD CAGE LEVELLING SOLENOID VALVE
<b>EV17</b>	REVERSE CAGE LEVELLING SOLENOID VALVE
<b>EV18</b>	JIB LIFTING SOLENOID VALVE
<b>EV19</b>	JIB LOWERING SOLENOID VALVE
<b>EV20</b>	DISPLACEMENT EXCHANGE SOLENOID VALVE
<b>EV21</b>	RIGHT CAGE ROTATION SOLENOID VALVE
<b>EV22</b>	LEFT CAGE ROTATION SOLENOID VALVE
<b>EV34</b>	BY-PASS SOLENOID VALVE
<b>EV38</b>	RIGHT STEERING SOLENOID VALVE
<b>EV39</b>	LEFT STEERING SOLENOID VALVE
<b>EV40</b>	BRAKE RELEASE SOLENOID VALVE
<b>EV41</b>	OSCILLATING AXLE RELEASE SOLENOID VALVE

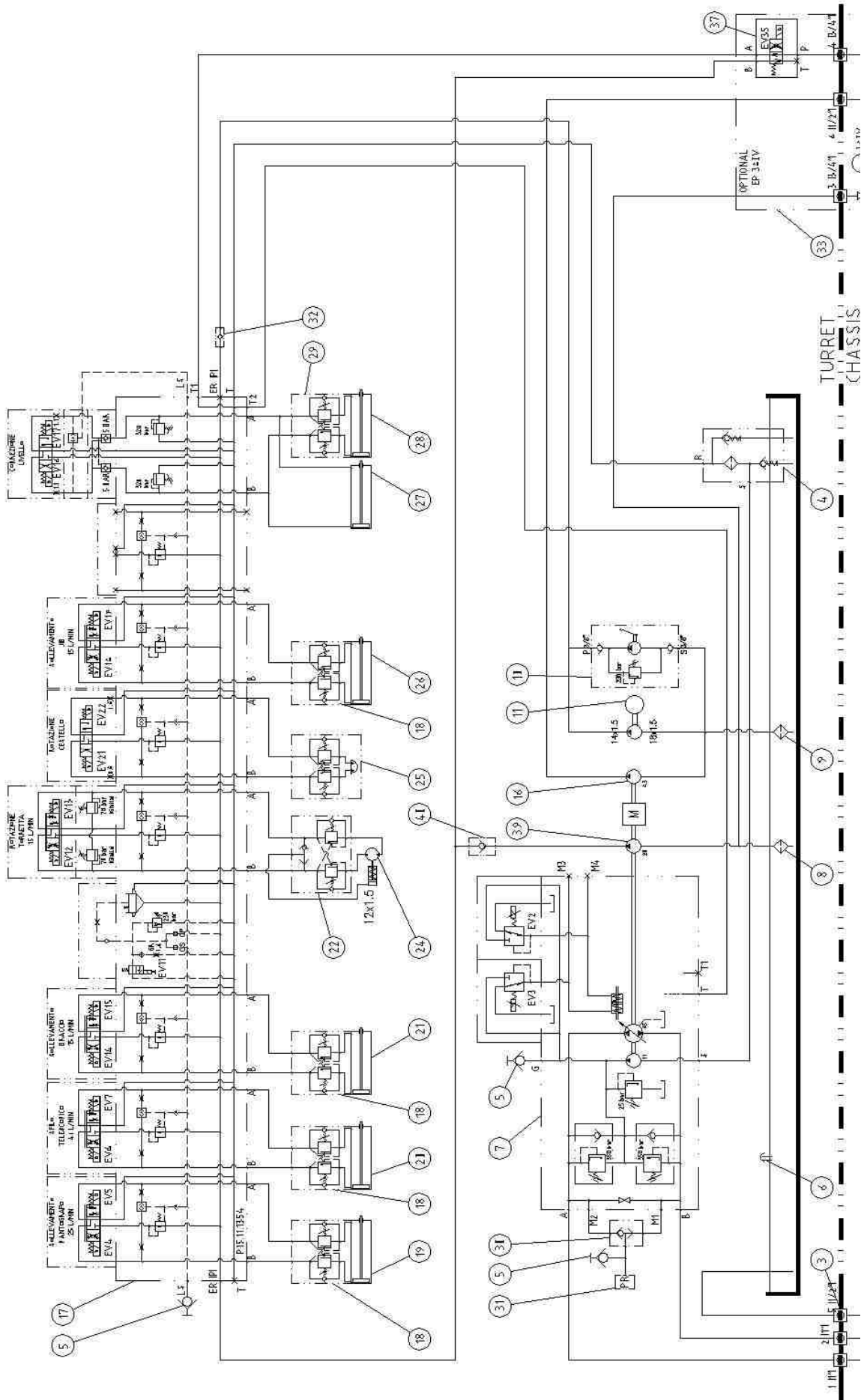

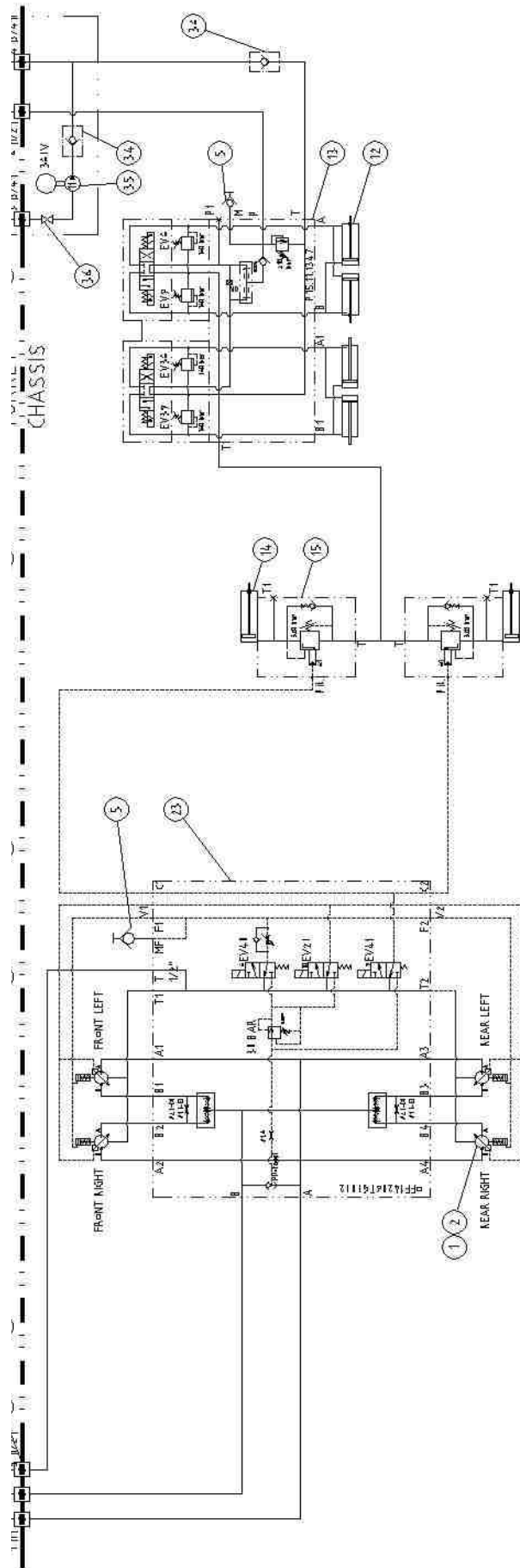

# 13. CONFORMITY DECLARATION

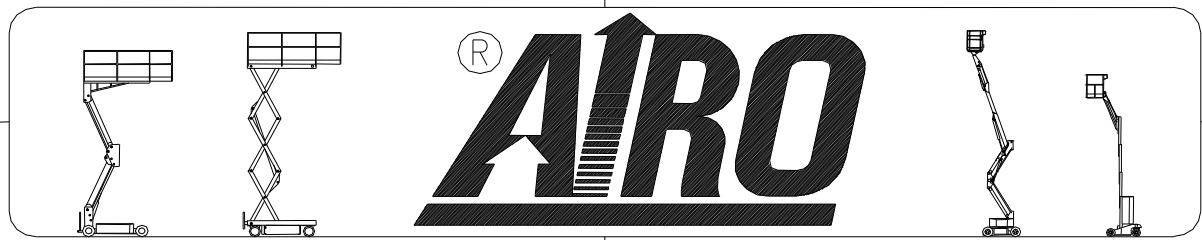

AIRO È UNA DIVISIONE TIGIEFFE SRL - VIA VILLA SUPERIORE, 82 -42045 LUZZARA (RE)

TEL. +39 0522 977365 FAX +39 0522 977015

**DICHIARAZIONE CE DI CONFORMITA' - CE DECLARATION OF CONFORMITY - DECLARATION CE DE CONFORMITE' - EG KONFORMITÄTSEKLRÄRUNG - DECLARACION CE DE CONFORMIDAD- ЗАЯВЛЕНИЕ О КОНФОРМНОСТИ EC 2006/42/CE**

Dichiarazione originale	Original Declaration	Déclaration Originale	Originalerklärung	Declaración Original	Оригинальная декларация
-------------------------	----------------------	-----------------------	-------------------	----------------------	-------------------------

Noi - We - Nous - Wir - Nosotros- мы

**Tigieffe S.r.l. - Via Villa Superiore N.° 82 - Luzzara (Reggio Emilia) - ITALIA**

Dichiaro sotto la nostra esclusiva responsabilità che il prodotto:	Declare under our exclusive responsibility that the product:	Declarons sous notre responsabilité exclusive que le produit:	Erklären hiermit unter Übernahme der vollen Verantwortung für diese Erklärung, daß das Produkt:	Declaramos bajo nuestra exclusiva responsabilidad que el producto:	Под нашу исключительную ответственность заявляем, что изделие:
--	--	---	---	--	--

Piattaforma di Lavoro Elevabile  
Mobile Elevating Work Platform  
Plates-forme Elévatrice Mobiles de Personnel  
Fahrbare Hubarbeitsbühnen  
Plataforma Elevadora Móvil de Personal  
Платформа для высотного работ

Modello - Model - Modèle Typ - Modelo-МОДЕЛЬ	N° Chassis - Chassis No. N° Chassis - Fahrgestellnr - N° Chassis - Номер Рама	Anno - Year - Année Vaujahr - Ano - Год
<b>A21 JRTD</b>	<b>XXXXXXXXXX</b>	<b>XXXXXXXXXX</b>

Al quale questa dichiarazione si riferisce è conforme alle direttive 2006/42/CE, 2014/30/CE, 2005/88/CE e al modello certificato da:	To which this declaration refers is in compliance with the directives 2006/42/CE, 2014/30/CE, 2005/88/CE and with the model certified by:	Faisant l'objet de la présente déclaration est conforme aux directives 2006/42/CE, 2014/30/CE, 2005/88/CE et au modèle certifié par	Auf das sich die vorliegende Erklärung bezieht, den 2006/42/CE, 2014/30/CE, 2005/88/CE Richtlinien und dem von:	Al cual esta declaración se refiere cumple las directivas 2006/42/CE, 2014/30/CE, 2005/88/CE y el modelo certificado por:	К которой это заявление относится, соответствует директивами 2006/42/CE, 2014/30/CE, 2005/88/CE и сертифицированной модели из:
--	---	---	---	---	--

ICE Spa Via Garibaldi, 20 40011 Anzola Emilia - BO (Italia)

**Identification No. 0303**

con il seguente numero di certificazione:	with the following certification number:	avec le numéro de certification suivant:	Zertifizierten Modell mit folgender Zertifizierungsnummer:	con el siguiente número de certificación:	со следующим сертифицированным номером:
---	--	--	--	---	---

N.Certificato - Certificate No. - N° du certificat - Bestätigungnummer - N° de certificado - Номер Сертификата

**M.0303.15.5830**

e alle norme seguenti:	and with the following standards:	et aux normes suivantes:	die Erklärung entspricht den folgenden Normen:	y a las siguientes normas:	и со следующими нормами:
------------------------	-----------------------------------	--------------------------	--	----------------------------	--------------------------

EN 280:2013 EN ISO 12100:2010 EN ISO 60204-1:2006

Il firmatario di questa dichiarazione di conformità è autorizzato a costituire il Fascicolo Tecnico.	The signatory of this conformity declaration is authorized to set up the Technical File.	Le signataire de cette déclaration de conformité est autorisé à constituer le Dossier Technique.	Der Unterzeichner dieser Konformitätserklärung ist autorisiert, das technische Unterlagen abzufassen.	El firmante de esta declaración de conformidad está autorizado a crear el Expediente Técnico.	Лицо, подписавшее это заявление о соответствии, уполномочено составить техническую документацию оборудования.
--	--	--	---	---	---

Luzzara (RE), data-date-date-Datum-fecha-Дата

Pignatti Simone

(Il legale rappresentante - The legal representative)



AIRO È UNA DIVISIONE TIGIEFFE SRL - Via Villa Superiore, 82 -42045 LUZZARA (RE)  
 TEL. +39 0522 977365 FAX +39 0522 977015

**DICHIARAZIONE CE DI CONFORMITÀ - CE DECLARATION OF CONFORMITY - DECLARATION CE DE CONFORMITE' -  
 EG KONFORMITÄTSEKLRÄRUNG - DECLARACION CE DE CONFORMIDAD- ЗАЯВЛЕНИЕ О КОНФОРМНОСТИ ЕС  
 2006/42/CE**

Dichiarazione originale	Original Declaration	Déclaration Originale	Originalerklärung	Declaración Original	Оригинальная декларация
-------------------------	----------------------	-----------------------	-------------------	----------------------	-------------------------

Noi - We - Nous - Wir - Nosotros- мы

**Tigieffe S.r.l. - Via Villa Superiore N.° 82 - Luzzara (Reggio Emilia) - ITALIA**

Dichiaro sotto la nostra esclusiva responsabilità che il prodotto:	Declare under our exclusive responsibility that the product:	Declarons sous notre responsabilité exclusive que le produit:	Erklären hiermit unter Übernahme der vollen Verantwortung für diese Erklärung, daß das Produkt:	Declaramos bajo nuestra exclusiva responsabilidad que el producto:	Под нашу исключительную ответственность заявляем, что изделие:
--	--	---	---	--	--

Piattaforma di Lavoro Elevabile  
 Mobile Elevating Work Platform  
 Plates-forme Elévatrice Mobiles de Personnel  
 Fahrbare Hubarbeitsbühnen  
 Plataforma Elevadora Móvil de Personal  
 Платформа для высотного работ

Modello - Model - Modèle Typ - Modelo-МОДЕЛЬ	N° Chassis - Chassis No. N° Chassis - Fahrgestellnr - N° Chassis - Номер Памы	Anno - Year - Année Waujahr - Ano - Год
<b>A21 JRTE</b>	<b>XXXXXXXXXX</b>	<b>XXXXXXXXXX</b>

Al quale questa dichiarazione si riferisce è conforme alle direttive 2006/42/CE, 2014/30/CE, 2005/88/CE e al modello certificato da:	To which this declaration refers is in compliance with the directives 2006/42/CE, 2014/30/CE, 2005/88/CE and with the model certified by:	Faisant l'objet de la présente déclaration est conforme aux directives 2006/42/CE, 2014/30/CE, 2005/88/CE et au modèle certifié par	Auf das sich die vorliegende Erklärung bezieht, den 2006/42/CE, 2014/30/CE, 2005/88/CE Richtlinien und dem von:	Al cual esta declaración se refiere cumple las directivas 2006/42/CE, 2014/30/CE, 2005/88/CE y el modelo certificado por:	К которой это заявление относится, соответствует директивами 2006/42/CE, 2014/30/CE, 2005/88/CE и сертифицированной модели из:
--	---	---	---	---	--

ICE Spa Via Garibaldi, 20 40011 Anzola Emilia - BO (Italia)

**Identification No. 0303**

con il seguente numero di certificazione:	with the following certification number:	avec le numéro de certification suivant:	Zertifizierten Modell mit folgender Zertifizierungsnummer:	con el siguiente número de certificación:	со следующим сертифицированным номером:
---	--	--	--	---	---

N.Certificato - Certificate No. - N° du certificat - Bestätigungnummer - N° de certificado - Номер Сертификата

**M.0303.15.5831**

e alle norme seguenti:	and with the following standards:	et aux normes suivantes:	die Erklärung entspricht den folgenden Normen:	y a las siguientes normas:	и со следующими нормами:
------------------------	-----------------------------------	--------------------------	--	----------------------------	--------------------------

EN 280:2013 EN ISO 12100:2010 EN ISO 60204-1:2006

Il firmatario di questa dichiarazione di conformità è autorizzato a costituire il Fascicolo Tecnico.	The signatory of this conformity declaration is authorized to set up the Technical File.	Le signataire de cette déclaration de conformité est autorisé à constituer le Dossier Technique.	Der Unterzeichner dieser Konformitätserklärung ist autorisiert, das technische Unterlagen abzufassen.	El firmante de esta declaración de conformidad está autorizado a crear el Expediente Técnico.	Лицо, подписавшее это заявление о соответствии, уполномочено составить техническую документацию оборудования.
--	--	--	---	---	---

Luzzara (RE), data-date-date-Datum-fecha-Дата

.....  
 Pignatti Simone

(Il legale rappresentante - The legal representative)





AIRO È UNA DIVISIONE TIGIEFFE SRL - Via Villa Superiore, 82 -42045 LUZZARA (RE)  
 TEL. +39 0522 977365 FAX +39 0522 977015

**DICHIARAZIONE CE DI CONFORMITA' - CE DECLARATION OF CONFORMITY - DECLARATION CE DE CONFORMITE' - EG KONFORMITÄTSEKLRÄRUNG - DECLARACION CE DE CONFORMIDAD- ЗАЯВЛЕНИЕ О КОНФОРМНОСТИ ЕС 2006/42/CE**

Dichiarazione originale	Original Declaration	Déclaration Originale	Originalerklärung	Declaración Original	Оригинальная декларация
-------------------------	----------------------	-----------------------	-------------------	----------------------	-------------------------

Noi - We - Nous - Wir - Nosotros- мы

**Tigieffe S.r.l. - Via Villa Superiore N.° 82 - Luzzara (Reggio Emilia) - ITALIA**

Dichiaro sotto la nostra esclusiva responsabilità che il prodotto:	Declare under our exclusive responsibility that the product:	Declarons sous notre responsabilité exclusive que le produit:	Erklären hiermit unter Übernahme der vollen Verantwortung für diese Erklärung, daß das Produkt:	Declaramos bajo nuestra exclusiva responsabilidad que el producto:	Под нашу исключительную ответственность заявляем, что изделие:
--	--	---	---	--	--

Piattaforma di Lavoro Elevabile  
 Mobile Elevating Work Platform  
 Plates-forme Elévatrice Mobiles de Personnel  
 Fahrbare Hubarbeitsbühnen  
 Plataforma Elevadora Móvil de Personal  
 Платформа для высотного работ

Modello - Model - Modèle Typ - Modelo-МОДЕЛЬ	N° Chassis - Chassis No. N° Chassis - Fahrgestellnr - N° Chassis - Номер Памы	Anno - Year - Année Waujahr - Ano - Год
<b>A23 JRTD</b>	<b>XXXXXXXXXX</b>	<b>XXXXXXXXXX</b>

Al quale questa dichiarazione si riferisce è conforme alle direttive 2006/42/CE, 2014/30/CE, 2005/88/CE e al modello certificato da:	To which this declaration refers is in compliance with the directives 2006/42/CE, 2014/30/CE, 2005/88/CE and with the model certified by:	Faisant l'objet de la présente déclaration est conforme aux directives 2006/42/CE, 2014/30/CE, 2005/88/CE et au modèle certifié par	Auf das sich die vorliegende Erklärung bezieht, den 2006/42/CE, 2014/30/CE, 2005/88/CE Richtlinien und dem von:	Al cual esta declaración se refiere cumple las directivas 2006/42/CE, 2014/30/CE, 2005/88/CE y el modelo certificado por:	К которой это заявление относится, соответствует директивами 2006/42/CE, 2014/30/CE, 2005/88/CE и сертифицированной модели из:
--	---	---	---	---	--

ICE Spa Via Garibaldi, 20 40011 Anzola Emilia - BO (Italia)

**Identification No. 0303**

con il seguente numero di certificazione:	with the following certification number:	avec le numéro de certification suivant:	Zertifizierten Modell mit folgender Zertifizierungsnummer:	con el siguiente número de certificación:	со следующим сертифицированным номером:
---	--	--	--	---	---

N.Certificato - Certificate No. - N° du certificat - Bestätigungnummer - N° de certificado - Номер Сертификата

**M.0303.15.5832**

e alle norme seguenti:	and with the following standards:	et aux normes suivantes:	die Erklärung entspricht den folgenden Normen:	y a las siguientes normas:	и со следующими нормами:
------------------------	-----------------------------------	--------------------------	--	----------------------------	--------------------------

EN 280:2013 EN ISO 12100:2010 EN ISO 60204-1:2006

Il firmatario di questa dichiarazione di conformità è autorizzato a costituire il Fascicolo Tecnico.	The signatory of this conformity declaration is authorized to set up the Technical File.	Le signataire de cette déclaration de conformité est autorisé à constituer le Dossier Technique.	Der Unterzeichner dieser Konformitätserklärung ist autorisiert, das technische Unterlagen abzufassen.	El firmante de esta declaración de conformidad está autorizado a crear el Expediente Técnico.	Лицо, подписавшее это заявление о соответствии, уполномочено составить техническую документацию оборудования.
--	--	--	---	---	---

Luzzara (RE), data-date-date-Datum-fecha-Дата

.....  
 Pignatti Simone

(Il legale rappresentante - The legal representative)



AIRO È UNA DIVISIONE TIGIEFFE SRL - VIA VILLA SUPERIORE, 82 -42045 LUZZARA (RE)

TEL. +39 0522 977365 FAX +39 0522 977015

**DICHIARAZIONE CE DI CONFORMITA' - CE DECLARATION OF CONFORMITY - DECLARATION CE DE CONFORMITE' - EG KONFORMITÄTSEKTLÄRUNG - DECLARACION CE DE CONFORMIDAD- ЗАЯВЛЕНИЕ О КОНФОРМНОСТИ ЕС 2006/42/CE**

Dichiarazione originale	Original Declaration	Déclaration Originale	Originalerklärung	Declaración Original	Оригинальная декларация
-------------------------	----------------------	-----------------------	-------------------	----------------------	-------------------------

Noi - We - Nous - Wir - Nosotros- мы

**Tigieffe S.r.l. - Via Villa Superiore N.° 82 - Luzzara (Reggio Emilia) - ITALIA**

Dichiaro sotto la nostra esclusiva responsabilità che il prodotto:	Declare under our exclusive responsibility that the product:	Declarons sous notre responsabilité exclusive que le produit:	Erklären hiermit unter Übernahme der vollen Verantwortung für diese Erklärung, daß das Produkt:	Declaramos bajo nuestra exclusiva responsabilidad que el producto:	Под нашу исключительную ответственность заявляем, что изделие:
<p>Piattaforma di Lavoro Elevabile Mobile Elevating Work Platform Plates-forme Elévatrice Mobiles de Personnel Fahrbare Hubarbeitsbühnen Plataforma Elevadora Móvil de Personal Платформа для высотного работ</p>					

Modello - Model - Modèle Typ - Modelo-МОДЕЛЬ	N° Chassis - Chassis No. N° Chassis - Fahrgestellnr - N° Chassis - Номер Памы	Anno - Year - Année Baujahr - Ano - Год
<b>A23 JRTE</b>	<b>XXXXXXXXXX</b>	<b>XXXXXXXXXX</b>

Al quale questa dichiarazione si riferisce è conforme alle direttive 2006/42/CE, 2014/30/CE, 2005/88/CE e al modello certificato da:	To which this declaration refers is in compliance with the directives 2006/42/CE, 2014/30/CE, 2005/88/CE and with the model certified by:	Faisant l'objet de la présente déclaration est conforme aux directives 2006/42/CE, 2014/30/CE, 2005/88/CE et au modèle certifié par	Auf das sich die vorliegende Erklärung bezieht, den 2006/42/CE, 2014/30/CE, 2005/88/CE Richtlinien und dem von:	Al cual esta declaración se refiere cumple las directivas 2006/42/CE, 2014/30/CE, 2005/88/CE y el modelo certificado por:	К которой это заявление относится, соответствует директивами 2006/42/CE, 2014/30/CE, 2005/88/CE и сертифицированной модели из:
--	---	---	---	---	--

ICE Spa Via Garibaldi, 20 40011 Anzola Emilia - BO (Italia)

**Identification No. 0303**

con il seguente numero di certificazione:	with the following certification number:	avec le numéro de certification suivant:	Zertifizierten Modell mit folgender Zertifizierungsnummer:	con el siguiente número de certificación:	со следующим сертифицированным номером:
---	--	--	--	---	---

N.Certificato - Certificate No. - N° du certificat - Bestätigungnummer - N° de certificado - Номер Сертификата

**M.0303.15.5833**

e alle norme seguenti:	and with the following standards:	et aux normes suivantes:	die Erklärung entspricht den folgenden Normen:	y a las siguientes normas:	и со следующими нормами:
------------------------	-----------------------------------	--------------------------	--	----------------------------	--------------------------

EN 280:2013 EN ISO 12100:2010 EN ISO 60204-1:2006

Il firmatario di questa dichiarazione di conformità è autorizzato a costituire il Fascicolo Tecnico.	The signatory of this conformity declaration is authorized to set up the Technical File.	Le signataire de cette déclaration de conformité est autorisé à constituer le Dossier Technique.	Der Unterzeichner dieser Konformitätserklärung ist autorisiert, das technische Unterlagen abzufassen.	El firmante de esta declaración de conformidad está autorizado a crear el Expediente Técnico.	Лицо, подписавшее это заявление о соответствии, уполномочено составить техническую документацию оборудования.
--	--	--	---	---	---

Luzzara (RE), data-date-date-Datum-fecha-Дата

.....  
Pignatti Simone

(Il legale rappresentante - The legal representative)



*Piattaforme Aeree Semoventi / Self-Propelled Aerial Platforms*

---

A series of horizontal lines for writing.



***AIRO*** is a division of **TIGIEFFE SRL**

Via Villasuperiore, 82 - 42045 Luzzara (RE) ITALIA-

☎ +39-0522-977365 - 📠 +39-0522-977015

WEB: [www.airo.com](http://www.airo.com) – e-mail: [info@airo.com](mailto:info@airo.com)