

SCISSORLIFT WITH DOUBLE DECK EXTENSION



X XL20 RTD



DIESEL^{4x4}

AIRO

SAFELY, HIGHER.

 MADE IN ITALY



↖ 2m

→ 7,4m

700kg



PERFORMANCES

High performance and versatility make this series particularly suitable for work on construction sites, but also for industrial maintenance work.

ADVANTAGES

The large double deck platform (up to 7.4m), total capacity of 700kg (including up to 6 persons), driveability up to the maximum working height, 4-wheel drive with oscillating axle guarantee excellent grip even on uneven terrain. A Stage V-compliant mechanical diesel engine enables low maintenance costs and low-emission operation. All advantages that place this series at the top of the industry.

VALUES

40 years of experience in design and manufacturing are a guarantee of reliability and durability.



Technical data

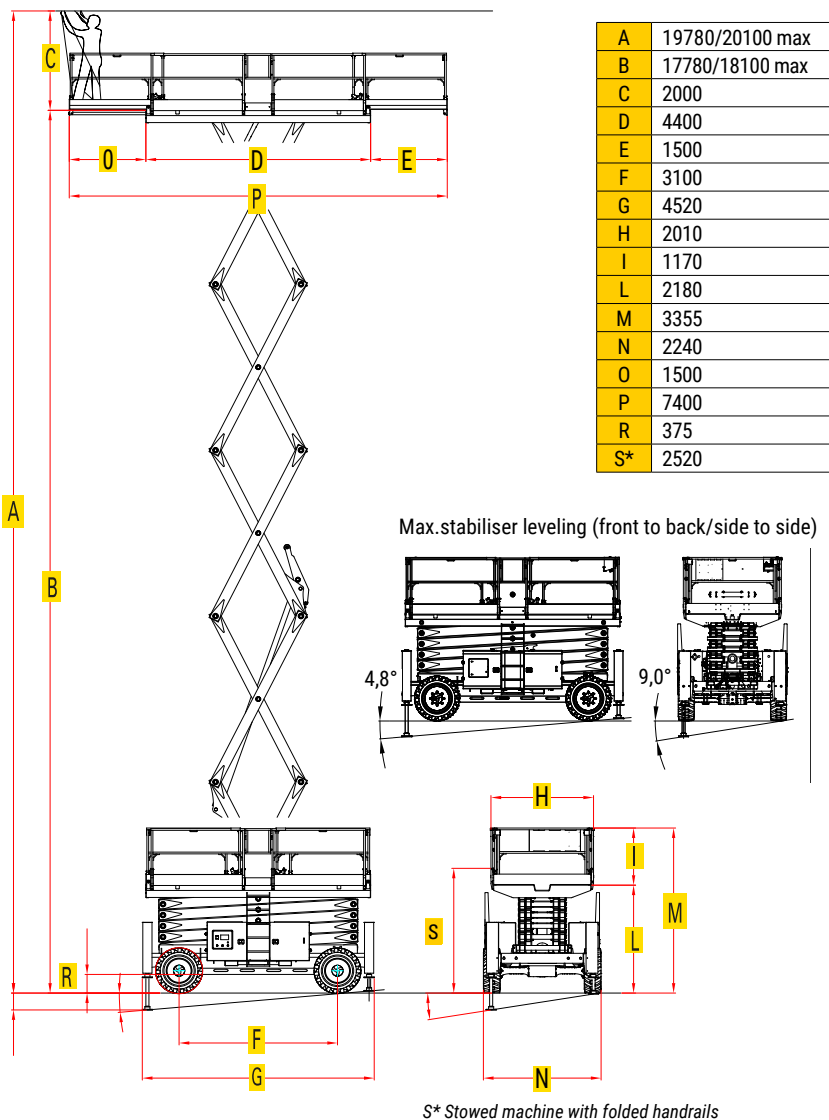

Standard Equipment

- Mechanical transmission with oscillating axle and 4WD / 2WS
- Proportional controls for drive, lifting and lowering
- Manual differential lock
- Huge deck with 2 lateral entry gates and foldable handrails
- Electric scissor protection
- Horn, hour meter and inclinometer
- Tilt switch dependent on travel height
- Pin based load limiter on platform
- Ground Control System with integrated diagnostics via touch screen (Advanced Touch Control System) with simple and intuitive icons
- Removable platform console with base connection for loading/unloading operations
- 4 Hydraulic stabilizers with automatic and manual levelling and flashing warning lights
- Lateral forklift pockets
- Anchorage and lifting points
- 230V electric line predisposition on the platform
- Black RT tyres SOLID AIR
- Telematic connector
- Declaration of conformity C€

Options & Accessories

- Control box protection cap
- 230V power line on platform
- 230V power line on platform with circuit breaker
- SAFE Secondary protection system
- Non marking RT tyres SOLID AIR
- Air/water line in platform with quick coupling
- Fleet management Kit
- Hydraulic Generator 3kVA 320V 50Hz
- Powered Dual Deck Extension
- DIESEL 24kW engine with DPF filter (YANMAR 3TNV88C)

TECHNICAL SPECIFICATIONS XL20 RTD

Max. working height	mm	19780
Max. platform height	mm	17780
Max. travel height	m	max
Total capacity /n° of persons	kg	700/6
Capacity on deck extension	kg	520/4
Manual roll-out extension deck, both sides	m	1,50
Lifting time	s	110
Lowering time	s	90
Power supply		Diesel YANMAR 3TN-V80F-SDSA 18,8kW
Starter battery	V/A	13/135
Battery charger	V/A	Diesel generator
Oil tank capacity	l	90
Fuel tank capacity	l	140
Drive speed (safety/fast)	Km/h	0,4/4,5
Inclination long. /trasv.	°	3-5/1,5 - 4
Gradeability	%	40
Inside / Outside turning radius	m	4,30/7,55
Tyres size /type	mm	Ø 300 Solid Air
Total weight	kg	11035

Remark: version without outriggers available on request

Tigieffe Srl follows a policy of continuous product improvement. Photographs used may represent version including accessories and options. Specifications are indicative and subject to change without notice. Some accessories or national standards may result in a weight increase. Technical specifications may vary according to national standards or in addition of optional version.

