



Piattaforme Aeree Semoventi / Self-Propelled Aerial Platforms

M/S

.....
.....

K.A.O Employer or Security Manager

Luzzara (RE) 3rd March 2018

Subject: Verification campaign on SG1100-JE – SG1400-J – SG1600-J – A13 JE – A16 J – A18 J

Construction year: from 2006 to 2012

Serial numbers: from SG0605216 to SG224407

Airo-Tigieffe after sales department, after the usual evaluations of the produced machines' status, verified that they are often used in a way that does not conform to their technical characteristics and to the instructions given in the specific manual (e.g. overload), or they suffer damages as a result of impacts with other structures.

Such improper use and possible suffered accidents could cause, in the machines included in the series indicated above in this letter subject, problems of structural resistance of the part called FLANGED ROTARY ACTUATOR on which the working platform is fixed.

Although the pre-operational visual verification of the structure is already foreseen among the legal obligations, it is recommended to the person in charge (user, owner, grantor, renter and other) to verify with the utmost promptness the particular mentioned according to the instructions that follow, and to put the machine out of service in case of doubts or fractures of which some examples are shown below.

If there are no obvious defects it is possible to continue working with the machine, but it is underlined the need to have the pre-operative visual check carried out scrupulously (as foreseen by the instruction manual and the technical standards in force) whenever you intend to use the machine, by the "Operator".

We kindly ask to the owner of the machines mentioned in the subject to make contact with our after-sales department.

Inspection procedure.

Place the machine on a horizontal and stable surface, with arms totally lowered.

Locate the FLANGED ROTARY ACTUATOR component indicated by the letter "A" in the image below.

Clean the highlighted areas (in particular the weld joints) from any residual grease, dirt and everything that could impede a correct inspection of the area.

Check the highlighted areas (especially the weld joints): there must be no fractures or cracks.

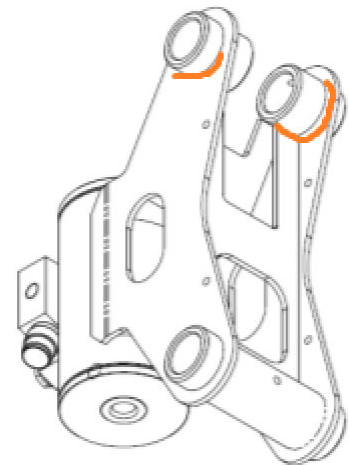
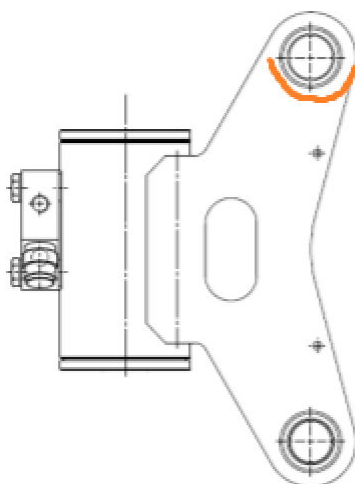
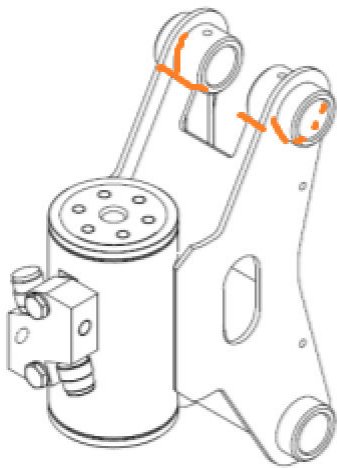
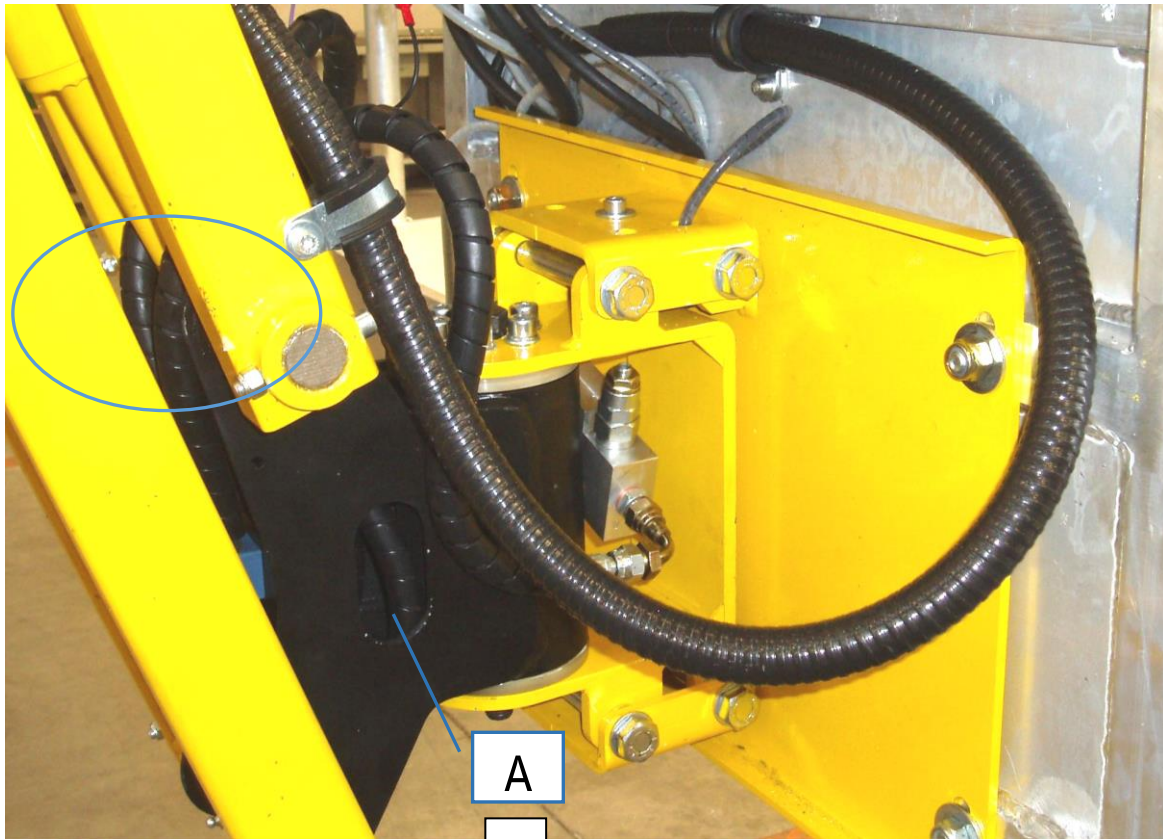



Piattaforme Aeree Semoventi / Self-Propelled Aerial Platforms

Costs/Warranties.

Please, refer to our general warranty conditions.

Property Changes.

This communication has been sent to the owners of the machines as per data in our possession. If in the meantime the machine had been sold to third parties, the recipients of the communication are invited to immediately report to AIRO-TIGIEFFE SRL the change of property in order to contact the new owners.

Further information.

For any further information or in order to communicate the change of property, please directly contact our after-sales department, at phone number +39-0522-977365 or e-mail to the address: service@airo.com indicating the reference to the subject of this communication.

AIRO-TIGIEFFE SRL
Luca Staffoli
(After-sales department manager)